

**BENZINA**

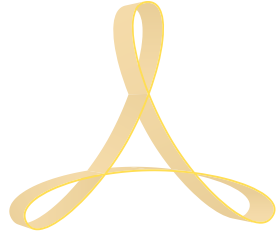

**A R C O B A L E N O™**

# PASTA COOKER | GAS MODEL APCG28/35

ONE-TANK ECO-FRIENDLY PASTA COOKER

Project: \_\_\_\_\_

Item #: \_\_\_\_\_

Qty: \_\_\_\_\_

CSI Section 11400: \_\_\_\_\_

Approval: \_\_\_\_\_

Date: \_\_\_\_\_

## STANDARD FEATURES

- Versatile pasta cooker; cook fresh, dry & frozen pastas plus... noodles, vegetables and more
- Stainless steel construction - sanitary finish
- Rounded corners, rear backsplash, and 316 stainless steel cooking tank
- 7 gallons for APCG28
- 11 gallons for APCG35
- Large diameter starch skimmer and drain
- Continuous water fill, large overflow safety valve, and floor drain
- 3 position temperature control
- Equipped with gas and Piezoelectric ignition, pilot light and thermocouple safety valves
- Factory and on-location training—the only full-service pasta machine manufacturer in North America

## OPTIONAL FEATURES & ACCESSORIES

- Robotic basket lift with adjustable digital timers (APCL)
- Casters Front 2 with locking brakes
- Casters Installed 2 front and 2 back
- Propane connection
- Restraining Kit
- Pasta trays
- 1 single point electric plug available with APCL28/35 Lift option
- Variety of pasta basket options



### Pasta Basket Options

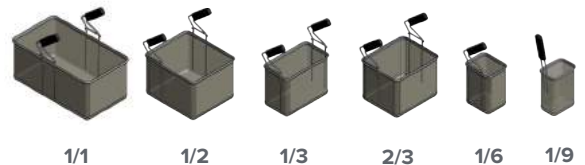

### Pasta Basket Combinations



### WARRANTY

**One Year:** For more information visit [arcobalenollc.com/warranty.html](http://arcobalenollc.com/warranty.html)



### TRY BEFORE YOU BUY

In an effort to ensure success, we maintain a test kitchen where you can have your very own recipe tested for quality —at NO COST to you! Call for details.



*Specifications subject to change without notice due to policy of continuous product improvement.*



ARCOBALENO®

# PASTA COOKER | GAS

## MODEL APCG28/35

ONE-TANK ECO-FRIENDLY PASTA COOKER

### TECHNICAL SPECIFICATIONS

<b>Model</b>	APCG28	APCG35
<b>Tank(s)</b>	1	1
<b>Tank Volume</b>	7 gallon	11 gallon
<b>Natural Gas Connection</b>	3/4" NPTF	3/4" NPTF
<b>Gas Pressure</b>	4" WC set @ burner max	4" WC set @ burner max
<b>Total Power</b>	32,400 BTU/h	47,600 BTU/h
<b>Water Connection</b>	3/4" NPTM	3/4" NPTM
<b>Water Draining</b>	1" NPTF	1" NPTF
<b>Tank Dimension</b>	12"W x 13.25"D x 12.5"H	12"W x 20"D x 12.75"H
<b>Machine Dimension</b>	15.75"W x 28.75"D x 36" H	15.75"W x 36.25"D x 36"H
<b>Shipping Dimension</b>	18"W x 31"D x 40"H	20"W x 39"D x 40"H
<b>Net Weight</b>	110 lbs	150 lbs
<b>Shipping Weight</b>	170 lbs	210 lbs
<b>Shipping Class</b>	85	85

### APCG28

NOTES:  
 A- GAS INLET, 3/4" NPT  
 B- WATER INLET, 3/4" NPT  
 C- WATER DRAIN, 1" NPT

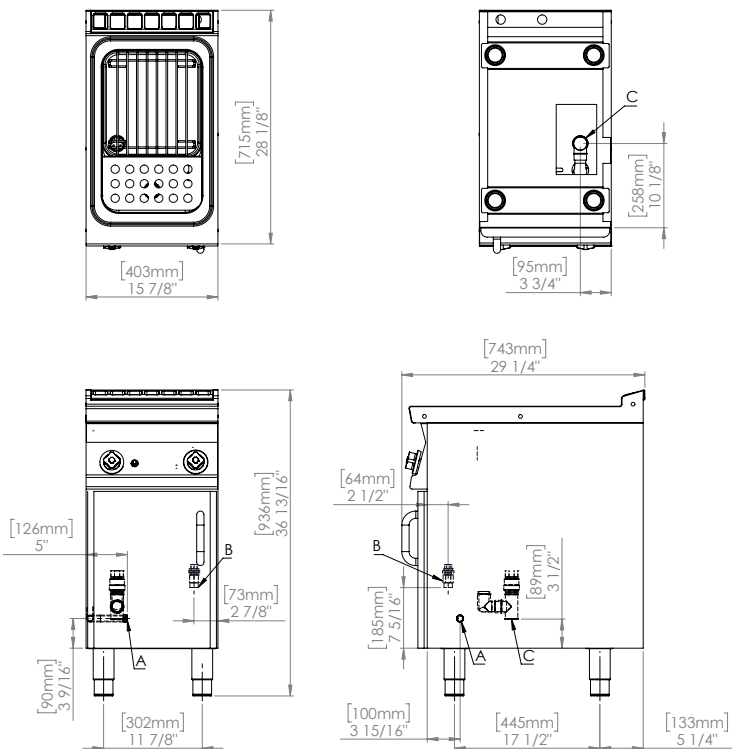

### APCG35

NOTES:  
 A- GAS INLET, 3/4" NPT  
 B- WATER INLET, 3/4" NPT  
 C- WATER DRAIN, 1" NPT

