

EXTRUDER + MIXER | INDUSTRIAL

DANIELLA - M



ARCOBALENO™
PASTA EQUIPMENT

AEX440M
FACTORY DUTY



STANDARD FEATURES

- Automatically mixes and extrudes all-in-one process! Fresh, flavorful pasta has never been easier or faster
- Machine equipped with double mixer for continuous production
- The extruder can produce dough sheets, single or double output, with variable or fixed thickness (optional lasagna sheet die)
- Water cooling feature to help maintain a constant extrusion temperature with digital temperature readout
- Removable auger & stainless steel mixing arm for easy cleaning
- Best selection of bronze dies guaranteed - **Over 400 shapes to choose from!**
- Factory and on-location training—the only full-service pasta machine manufacturer in North America
- Touch screen control

TOUCH SCREEN FEATURES

- Pre-set pasta shape recipes
- Different cutting speeds for pasta shape sizes
- Variable speed on mixing + extruding
- Alarms indicating emergency button pushed, errors, etc.

OPTIONAL FEATURES & ACCESSORIES

- Automatic cutting knife for short pastas
- Lasagna Sheet Die Adjustable or Fixed Thickness
- Guillotine Timer Cutter for Long Pastas & Noodles
- Penne Die with Special Cutting Knife
- Vacuum System
- Rolling Pins
- APC-20 Mobile pasta cart with 20 trays
- Pasta trays - solid and perforate
- Optional water chiller mobile system



TOUCH SCREEN CONTROL



OPTIONAL WATER CHILLER MOBILE SYSTEM

EXTRUDER + MIXER | INDUSTRIAL



AEX440M TECHNICAL SPECIFICATIONS

Model	AEX440M
Hourly Production	Up to 440 lbs/hr lbs
Front Mixer Production (flour+liquid)	110 lbs per batch
Top Mixer Production (flour+liquid)	110 lbs per batch
Electrical Power	208V/3/60Hz 38 Amps 240V/3/60Hz 24 Amps
Nema Plug	L15-20
Cord Length	8 ft
Machine Dimension	52" w x 73" D x 69" H
Shipping Dimension	60" w x 77" D x 75" H
Net Weight	1323 lbs
Shipping Weight	1690 lbs
Shipping Class	85

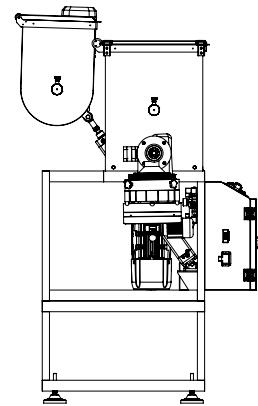

VARIABLE MIXING + EXTRUDING SPEEDS



PRE-SET PASTA SHAPE RECIPES



ALARMS INDICATING ERRORS

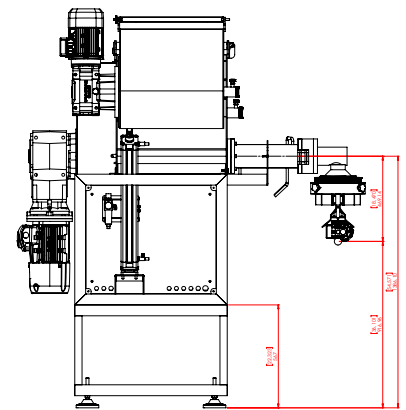

WARRANTY

One Year: For more information visit arcobalenollc.com/warranty.html



TRY BEFORE YOU BUY

In an effort to ensure success, we maintain a test kitchen where you can have your very own recipe tested for quality — at NO COST to you! Call for details.



CAD file available. Please contact factory 717-394-1402. | Specifications subject to change without notice | © Copyright 2019 Arcobaleno™, LLC