



**ARCOBALENO<sup>®</sup>**  
PASTA EQUIPMENT

# MODEL APCG35HA OPERATING, INSTALLATION & MAINTENANCE MANUAL



Intertek

Intertek

CONFORMS TO UL STD 197; NSF/ANSI STANDARD 4  
CERTIFIED TO CSA STD C22.2 #109

## IMPORTANT SAFETY NOTICE

This manual contains important safety instructions which must be strictly followed when using this equipment.

## FOR SERVICE, CONTACT ARCOBALENO

If you have any questions or issues regarding your machine, please contact us at: **717.394.1402** or **service@arcobalenollc.com**. When contacting us, please have your serial number and model number available so we can assist you based on your machine's individual specifications.



A R C O B A L E N O<sup>®</sup>

## Arcobaleno Machine Certification

The following machine(s) have been inspected and tested by Arcobaleno prior to shipment to customer:

Model number(s): \_\_\_\_\_

Serial Number(s): \_\_\_\_\_

And found to meet the following requirements as certified by the undersigned.

- Machine power connections are installed correctly
- The machine has been tested
- An operating manual has been included in the packaging
- Appropriate tools have been included in the packaging
- The machine has been packaged properly and is free of physical defects

Authorized Arcobaleno Representative Signature: \_\_\_\_\_

Date: \_\_\_\_\_



ARCOBALENO®

## SAFETY NOTICE/WARRANTY

### MODEL APCG35HA

#### IMPORTANT SAFETY NOTICE

To insure both safe and trouble-free performance, we stress that all personnel that will be involved with your new Arcobaleno Pasta Machine **must** read and understand these instructions **before** attempting to operate this unit.

#### LIMITED WARRANTY

**Warranty Effective only when Certificate of Acceptance is received.**

**Please mail back with enclosed pre-paid envelope.**

**If not received within 14 days warranty is VOID.**

ARCOBALENO, LLC. guarantees this device against defects in workmanship or material under use and service **for a period of twelve (12) months, which begins upon receipt of machine by the customer.** All obligations and liabilities under this guarantee are limited to repairing or replacing, at our option, F.O.B. our plant of such allegedly defective units as are returned and carrier charges prepaid. All repairs or replacements are made subject to factory inspection of returned parts at company plants. No liability is accepted for consequential damage which may include but is not limited to: damage or failure that has occurred due to misuse, acts of God, damage due to reinstallation labor or improper application. This warranty does not include electrical parts. Defects as defined in the above paragraph shall not include decomposition by chemical action (corrosion).

In the event that a defect in material or workmanship occurs during the first ninety (90) days of the warranty and if Arcobaleno determines that field service is required, Arcobaleno will provide the required service and parts free of charge. The buyer will be responsible for and invoiced for all out of pocket travel and living expenses incurred by such a service call. After the initial ninety (90) days of the warranty, Arcobaleno will service the equipment at the customer's facility at its prevailing labor rates plus expenses. A purchase order will be required for any parts or service ordered under this warranty.

Defects due to materials or manufacturing shall be examined at our expense but if the claim is unjustified, all repairs and replacement costs have to be borne by the customer. The guarantee does not cover accidental damage, negligence or inappropriate treatment, incorrect use or phenomena not depending on the regular functioning or use of this machine.

Guarantee on equipment and accessories furnished by outside manufacturers shall be limited to the guarantees of the respective equipment and/or accessory manufacturer for such units. This guarantee is null when the machine has been repaired by non-authorized personnel and/or when spare parts have been supplied that have not been approved by the manufacturer.

#### FOR WARRANTY SERVICE

Contact the Arcobaleno warranty service department at **(800) 875-7096** or **(717) 394-1402** to report warranty claims before arranging repair or attempting to return the unit to Arcobaleno, LLC.



ARCOBALENO®

## IMPORTANT SAFETY WARNINGS

### MODEL APCG35HA

1.48.1 a

**FOR YOUR SAFETY**

Do not store or use gasoline or other flammable vapors or liquids in the vicinity of this or any other appliance.

**WARNING**

Improper installation, adjustment, alteration, service or maintenance can cause property damage, injury or death. Read the installation, operating and maintenance instructions thoroughly before installing or servicing this equipment.

The installation must conform with local codes, or in the absence of local codes, with the National Fuel Gas Code, ANSI Z223.1/NFPA 54, or the Natural Gas and Propane Installation Code, CSA B149.1, as applicable.

The appliance and its individual shutoff valve must be disconnected from the gas supply piping system any pressure testing of that system at test pressure in excess of ½ psi (3,5 kPa).

The appliance must be isolated from the gas supply piping system by closing its individual manual shutoff valve during any pressure testing of the gas supply piping system at test pressures equal to or less than ½ psi (3.5 kPa).

1.48.1 a

The purchaser must post in a prominent location instructions to be followed in the event the user smells gas.

This information shall be obtained by consulting the local gas supplier.

The appliance, when installed, must be electrically grounded in accordance with local codes, or in the absence of local codes, with the National Electrical Code, NFPA 70, or the Canadian Electrical Code, CSA C22.2, as applicable.

**WARNING**

The equipment is to be installed with adequate backflow protection to comply with applicable federal, state, and local codes.



ARCOBALENO®

## TABLE OF CONTENTS

### MODEL APCG35HA

Section 1 GENERAL INFORMATION .....	6
Section 2 PRELIMINARY INFORMATION .....	10
Section 3 TECHNICAL DESCRIPTION & OPERATION.....	13
Section 4 INSTALLATION & START UP.....	16
Section 5 USE OF THE MACHINE .....	27
Section 6 MAINTENANCE.....	35
Section 7 ADDITIONAL USAGE GUIDELINES.....	38
Section 8 SCRAPPING & DISPOSAL, PARTS & ELECTRICAL DIAGRAMS .....	42

#### PASTA COOKER LIGHT:

- The red light indicates the presence of water. It will flash once after the unit is powered on.

Out = Presence of water detected

Flashing = Actively searching for water

Solid = Water not detected, turn machine off (green on-off switch) for 20 seconds to reset

**Note:** If water is present in the tank but not detected, it is necessary to turn off the machine, drain the water, and clean the water sensors with a scrub pad. The water sensors are on the front wall of the tank, which is visible when leaning over the front of the pasta cooker. Any questions, please call Arcobaleno.



**Water Sensor**



**A R C O B A L E N O<sup>®</sup>**

**GENERAL INFORMATION**  
MODEL APCG35HA

**SECTION 1**

GENERAL..... 7  
PURPOSE OF MANUAL..... 7  
WHERE & HOW TO KEEP THIS MANUAL..... 7  
MANUAL UPDATE..... 8  
COOPERATION WITH THE USER..... 8  
MANUFACTURER’S WARRANTY ..... 8  
AFTER-SALE SERVICE ..... 9

**1.1 GENERAL**

This publication, hereinafter simply defined as the “manual”, includes any information regarding installation, use, and maintenance of the “APCG35HA” manufactured by Arcobaleno Pasta Machines, LLC.

The recipients of this publication, generally defined as “users”, include all individuals who, according to their relevant involvement, need and/or are required to provide instructions or to attend this machine operationally.

These individuals can be identified as follows:

- ✓ Directors
- ✓ Chief of Operations
- ✓ Heads of Department
- ✓ Machine operators who are directly involved in its transportation, storage, installation, use, and maintenance, starting from its market introduction until its service
- ✓ Private direct users

This publication must be considered as being an integral part of the machine and, as such, it needs to be kept for future references until final dismantling and scrapping of the machine.

**1.2 PURPOSE OF MANUAL**

The purpose of this manual is to allow specific individuals to learn how to use this machine safely for a long period of time in order to perform any relevant tasks; provided that such individuals shall take any measure and arrange in advance any human resources and materials as necessary. The machine’s intended use and configuration are the only ones approved by the manufacturer; users are advised to avoid usage of the machine in a way non-compliant with the instructions given. Every other use or configuration should be previously agreed with the manufacturer and, in such case, an Annex will be attached to this manual. The machine operator shall comply with any applicable labor law in force at the machine’s place of installation.

**1.3 WHERE AND HOW TO KEEP THIS MANUAL**

This manual should be kept in a safe and dry area where it is always available for consultation. It is advisable to make a copy which should be kept on file. In the event of exchanges of information taking place with the manufacturer, please refer to the rating plate and serial number. This manual should be kept for the entire life of the machine, and if needed, (for example damage that compromises its consultation, even if only partially, etc.), the user must purchase a new copy which should be requested to the manufacturer only.



ARCOBALENO®

## GENERAL INFORMATION

### MODEL APCG35HA

#### 1.4 MANUAL UPDATE

This manual forms an integral part of the machine and reflects its current status upon its market introduction. This publication complies with any law, directive, regulations in force at that time; it shall not be deemed unsuitable if updated at a later time.

Any changes, adjustments, etc. made on machines marketed afterwards shall cause the manual to be reviewed, however, any manual always represents the current condition of the machine associated with it.

Any additions to this manual that the manufacturer considers appropriate to send to every user should be kept in conjunction with its relative manual.

#### 1.5 COOPERATION WITH THE USER

The manufacturer is available for any additional information its clients may have and for taking into consideration any suggestion as to improve its products and to make this manual more responsive to users needs. In case of equipment transfer, the equipment should be accompanied by this manual. In this regard, the principal user should send the address of the new user to the manufacturer, so that the manufacturer will be able to provide him/her with any necessary information and/or updates.

Arcobaleno Pasta Machines, LLC. reserves title to this publication and warns against any reproduction, in whole or in part, without its prior written consent.

#### 1.6 MANUFACTURER'S WARRANTY

In order to benefit from the manufacturer's warranty, users should strictly comply with any provision set forth in this manual, in particular such as:

- ✓ To operate the machine within its usage limits
- ✓ To carry out regular and accurate maintenance
- ✓ To select qualified personnel having the necessary skills and capabilities and being appropriately trained to use this machine

The manufacturer accepts no responsibility, direct or indirect, arising from:

- ✓ Non-compliance with operating instructions and uses which differ from those provided in this manual
- ✓ Usage from personnel unaware of any instructions and details included in this manual
- ✓ Non-compliant usage with specific regulations in force in the installation country
- ✓ Changes made on the machine without prior authorization
- ✓ Unauthorized repairs
- ✓ Use of unoriginal parts
- ✓ Exceptional events



ARCOBALENO®

## GENERAL INFORMATION

### MODEL APCG35HA

Any transfer of the machine to a second user shall take place in conjunction with its related manual; the lack of it shall automatically cause decline of any responsibility on the part of the manufacturer for any incorrect use of the machine.

If the machine is transferred to a second user residing in a country whose language differs from the country of the first user, such first user shall be responsible for providing the second user with a reliable translation of this manual in the language of the country where the machine is transferred to.

### 1.7 AFTER-SALE SERVICE

For any after-sale service please refer directly to the manufacturer at the following address:

Arcobaleno Pasta Machines, LLC.  
160 Greenfield Road  
Lancaster, PA 17601

Tel: 717.394.1402  
Fax: 717.397.0258

[service@arcobalenollc.com](mailto:service@arcobalenollc.com)  
[www.arcobalenollc.com](http://www.arcobalenollc.com)

**AFTER HOURS TECH SUPPORT** contact Antonio at 610.656.0391



**A R C O B A L E N O<sup>®</sup>**

**PRELIMINARY INFORMATION**  
MODEL APCG35HA

**SECTION 2**

COMPLIANCE OF RATING PLATES - LABELING .....11  
PACKING - HANDLING..... 12  
STORAGE UPON RECEIPT..... 12  
MACHINE AND SUPPLY KIT INSPECTION ..... 12

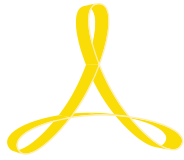

ARCOBALENO®

## PRELIMINARY INFORMATION

### MODEL APCG35HA

#### 2.1 COMPLIANCE OF RATING PLATES - LABELING

As shown in particular in A, the rating plate includes main data on the manufacturer and on the machine in addition to the ETL labeling. The data plate is found on the front side, by opening the door. The data plate includes the model number (Mod.) and serial number (Nr.).

As shown in particular in B, other rating plates are added in order to display general warnings as to the correct use of the machine.

#### Readability and preservation of rating plates:

Rating plates should always be kept in readable form concerning all data included. For such purpose, they should be cleaned on a regular base. In case of degradation and/or illegibility of any one piece of information included, users should request another plate from the manufacturer. Upon such request, they should mention the details included in the original plate and arrange for its substitution.

**WARNING: The below rating plates should not be removed or covered with others.**



A



B

#### Additional warnings to follow:

**WARNING**

**DO NOT LIGHT THE PILOT WITH THE WATER TANK EMPTY.**

Damage to the tank from heating while empty will not be covered under warranty.

**WARNING**

**PRIOR TO DRAINING PASTA COOKER: TURN MACHINE OFF.**

**A. Wait 10 minutes OR until water reaches 140°F (60°C) before draining.**

**B. Add 1 gallon of cold water before draining.**

**Failure to do so will result in machine damage and will void the warranty.**



ARCOBALENO®

## PRELIMINARY INFORMATION

### MODEL APCG35HA

#### 2.2 PACKING - HANDLING

Machines are delivered completely assembled so that packaging and/or special protections are not included in the delivery. In case of different agreements between the manufacturer and the user regarding packing of parts or the entire machine as well as handling, see any specific instructions attached to this publication.

#### 2.3 STORAGE UPON RECEIPT

Storage can take place soon after delivery of the machine and is allowed for a maximum period of two years in sheltered areas with the following features:

- The storage area should be a sheltered place with a temperature of no less than 41° F / 5° C and not over 104° F / 40° C, with a humidity ratio not exceeding a value equal to 80%.
- Should the above mentioned values change in the course of storage, performing some preliminary checks shall be required before setting the machine at work (please consult with the manufacturer).
- Should the temperature within the storage area exceed or drop below the above mentioned values and the relative humidity goes over 80%, it shall be necessary to take proper measures such as using a bag barrier and hygroscopic salt.

**WARNING: For storage periods longer than two years or under different environmental conditions, please request the relevant preservation procedures from the manufacturer.**

#### 2.4 MACHINE AND SUPPLY KIT INSPECTION

The machine and its relative supply kit (as agreed with the manufacturer) should be in perfect condition. Before shipping, each item is carefully checked and inspected, however, upon its receipt, it is always advisable to verify the completeness and working condition of the goods shipped.

**In case of any defects and/or incompleteness, please inform the manufacturer immediately and comply with his instructions before proceeding with the installation of the machine.**

Verify any possible damages to the frame, buckles, etc. cracks or tears of electrical conductors, etc... Take the machine's documentation and verify the absence or any discrepancy between what is stated in the shipping documents and the goods received.

Standard supply kit:

- ✓ Machine Certification
- ✓ Certificate of Acceptance - Please mail back with enclosed pre-paid envelope.  
If not received with-in 14 days warranty is VOID.
- ✓ Operator's manual - installation, usage, and maintenance
- ✓ ETL Electric and Sanitation Approval



**TECHNICAL DESCRIPTION  
& OPERATION**  
MODEL APCG35HA

**SECTION 3**

GENERAL FEATURES AND OPERATING TIPS.....14  
TECHNICAL DATA.....14  
MACHINE CONFIGURATION..... 15  
EXPECTED USE - INTENDED USE..... 15  
USERS ..... 15



## TECHNICAL DESCRIPTION & OPERATION

### MODEL APCG35HA

### 3.1 GENERAL FEATURES AND OPERATING TIPS

The most efficient installation of your Arcobaleno Pasta Cooker will depend upon the layout of your kitchen. Locate your Pasta Cooker where it will save steps for the operator and be sure to provide sufficient clearance around it for ease of maintenance and cleaning, as well as for efficient and safe use.

- Keep the work area free and clear of combustibles.
- Gas installations, the electrical connections and the rooms in which the appliances are installed must comply with the norms in force in the Country in which the installation is carried out; above all, the appliance must be installed in a well ventilated room, preferably under an extractor hood, so as to ensure the complete extraction of gas emissions which are formed during combustion.

**⚠ WARNING DO NOT LIGHT THE PILOT WITH THE WATER TANK EMPTY.**  
Damage to the tank from heating while empty will not be covered under warranty.

**⚠ WARNING PRIOR TO DRAINING PASTA COOKER: TURN MACHINE OFF.**  
A. Wait 10 minutes OR until water reaches 140°F (60°C) before draining.  
B. Add 1 gallon of cold water before draining.  
Failure to do so will result in machine damage and will void the warranty.

### 3.2 TECHNICAL DATA

Model	APCG35HA
Tank	1
Tank Volume	11 gallon
Tank Dimensions	12.25"W x 20.25"D x 13"H
Natural Gas/LP Connection	1/2" NPTM (Qty: 1)
Natural Gas/LP Pressure	7" WC max NG / 11" WC max LP
Total Gas Power	80,185 BTU
Total Electric Power	120V/1/60Hz 0.018kW (0.29 Amps @ 120V)
Nema Plug	5-15P
Water Connection*	3/4" NPTM (Qty: 1)
Water Pressure	14.5 - 72.5 psi
Water Draining	1" NPTM (Qty: 1)
Machine Dimensions	15.75"W x 35.50"D x 45"H
Shipping Dimensions	17"W x 38"D x 50.25"H
Machine Weight	150 lbs
Shipping Weight	200 lbs
Shipping Class	85



## TECHNICAL DESCRIPTION & OPERATION MODEL APCG35HA

### 3.3 MACHINE CONFIGURATION

All machines are exclusively marketed under the configurations set forth in this manual.

### 3.4 EXPECTED USE - INTENDED USE

This machine is intended for cooking pasta. The use herein indicated is the only one recognized by the manufacturer. In the event that the manufacturer and the user agreed on specific operating conditions, these will be documented and enclosed as annexes to the machine manual, thus forming an integral part of it.

### 3.5 USERS

In selecting the most appropriate person (operator) to operate the machine, who will necessarily be someone fit for work in compliance with the regulations in force, the individual in charge of company security shall take into consideration the physical aspect (no impairment), the psychological aspect (mental balance, sense of responsibility), as well as the educational level, training, experience, and knowledge of rules, instructions, and measures designed for accident prevention.

Based on the dispositions and skills emphasized by the operator, the individual in charge of company security shall arrange for his/her training on the machine as to provide him/ her with a complete knowledge of this machine.

In addition the operator will learn the content of this manual as well as its attachments.

**WARNING:** Don't allow anyone to approach the area when the machine is working and forbid its usage to individuals unfamiliar with ongoing operations.



**ARCOBALENO®**

# **INSTALLATION & START UP**

## **MODEL APCG35HA**

### **SECTION 4**

PRELIMINARY CHECKS .....17

INSTALLATION'S MANUAL.....17

PRESSURE REGULATOR ..... 18

INSTALLATION ..... 19

WATER SUPPLY CHARACTERISTICS ..... 20

WATER CONNECTION AND DRAINAGE..... 20

CHECKING FOR CORRECT VENTILATION AND COMBUSTION AIR..... 20

PIPE FOR GAS CONNECTION ..... 21

CHECKING HEAT OUTPUT ..... 21

RULES FOR CONVERTING AND INSTALLING FOR OTHER TYPES OF GAS..... 22

CHECKING FUNCTIONING..... 22

INSTRUCTIONS FOR INSTALLATION .....23

LAWS, TECHNICAL RULES AND NORMS..... 24

ELECTRIC CONNECTION ..... 24

EQUIPOTENTIAL ..... 24

INSTRUCTIONS FOR DISCHARGING GAS EMISSIONS ..... 24

LIQUID PROPANE SET UP (OPTIONAL, UPON REQUEST)..... 26



ARCOBALENO®

## INSTALLATION & START UP

### MODEL APCG35HA

#### 4.1 PRELIMINARY CHECKS

- Verify the integrity and perfect condition (no signs of rust, humidity, dent, etc.) of both the machine and of any anticipated accessories within the consignment.
- Assess the integrity of the electric installation wiring (no signs of cracks, squashes, etc.)
- Verify that the expected way to get to the installation place (machine handling) is free from any possible obstacles (things or persons). Foresee contingent protection barriers and get to the selected installation place.

#### 4.2 INSTALLATION'S MANUAL

1.48.1 d Keep the appliance area free and clear from combustibles.

1.48.1 e Not obstruct the flow of combustion and ventilation air.

1.48.1 f This manual shall be retained for future reference.

The manufacturer declines any responsibility for direct or indirect damage caused by improper or incorrect installation, alterations, maintenance or use of the appliance, as in all the other cases considered in the items of our sales conditions.

An enlarged diagram detailing the locations of the electrical connection, gas connection, water connection, and water drainage can be found on page 44 of this manual.

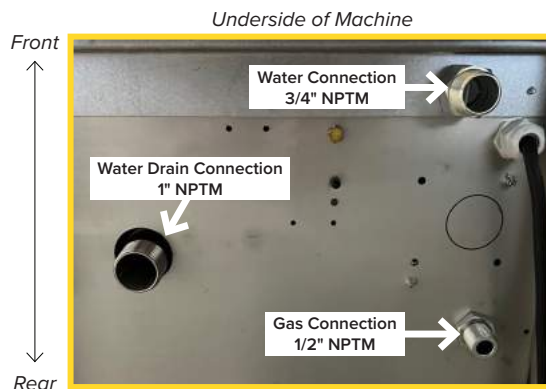
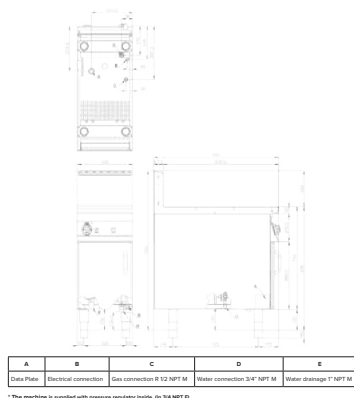



ARCOBALENO®

# INSTALLATION & START UP

## MODEL APCG35HA

### 4.3 PRESSURE REGULATOR

The machine is supplied with pressure regulator inside. (in 3/4 NPT F)

**WARNING:** Supply Inlet Pressure = 12~13 iwc (Natural Gas)  
 Outlet Pressure of Regulator = 4 inch water (Natural Gas)

See also attached illustrative sheet to the pressure regulator.

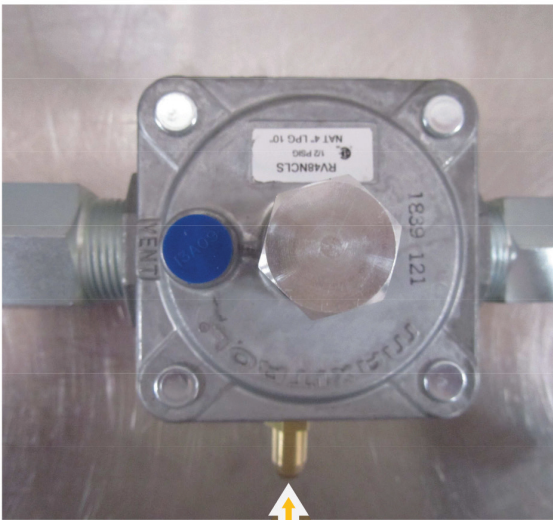
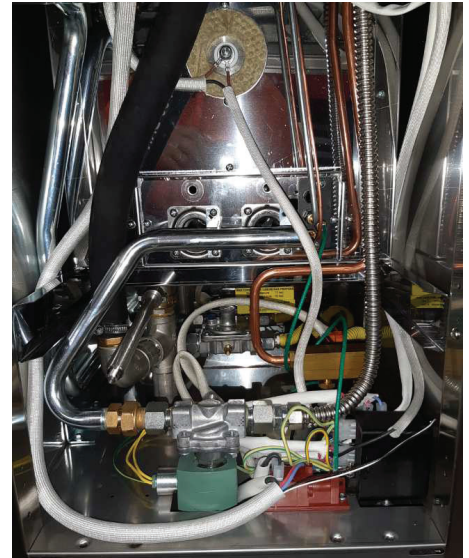

↑ Check point pressure outlet 1/8 NPT

**NOTE:** GAS A = Natural gas (pressure at the outlet of the regulator) = 4 inch water

**NOTE:** GAS E = Propane gas (optional, on request) (See page 27, Section 4.17 - Liquid Propane Set Up)

### TECHNICAL GAS DATA TABLE

Model	APCG35HA
Dimensions	15.75"W x 35.50"D x 35.50"H
Total Nominal Power (BTU/h)	80,185
Gas Connection *	R 1/2 NPT M
Water Filling P min = 100 Kpa = 14.5 psi = 400 iwc P max = 500 Kpa = 72.5 psi = 2000 iwc	R 3/4 NPT M
Water Drainage	1 NPT M

\* The machine is supplied with pressure regulator inside (in 3/4 NPT F)

**WARNING:** Supply Inlet Pressure = 12~13 iwc (Natural Gas)



ARCOBALENO®

## INSTALLATION & START UP

### MODEL APCG35HA

#### 4.4 INSTALLATION

1.48.1 i, p The appliance must be installed in accordance with the ANSI Z83.11•CSA 1.8(2016) Gas Food Service Equipment.

Proceed with the machine setting in the area specifically designed pursuant to instructions given in Section 2 of this manual.

- The operations for installing, conversions for use with other types of gas and starting up must be done only by qualified personnel whose qualifications comply with the norms in force.
- Gas installations, the electrical connections and the rooms in which the appliances are installed must comply with the norms in force in the Country in which the installation is carried out; above all, the appliance must be installed in a well ventilated room, preferably under an extractor hood, so as to ensure the complete extraction of gas emissions which are formed during combustion. The air necessary for combustion is 2m<sup>3</sup> /h per kW of power installed.

**ATTENTION!** In accordance with international rules, when connecting the appliance, an automatic device enabling the disconnection of all contacts from the mains, must be installed above it; this device must have a contacts opening of at least 3 mm.

**FOR YOUR SAFETY!** Do not store or use gasoline or other flammable vapors or liquids in the vicinity of this or any other appliance.

**WARNING:** Improper installation, adjustment, alteration, service or maintenance can cause property damage, injury or death. Read the installation, operating and maintenance instructions thoroughly before installing or servicing this equipment.

The customer is responsible for the installation. The installation must be performed by qualified personnel.

#### Operator

This machine requires only one operator for the installation.

During normal working order the operator must stay in its proximity, at “visual” distance in order to intervene in case of malfunction or loading/downloading operations, as the case may be.

#### Lighting System

This machine is not equipped with an off-the-shelf lighting system. The lighting level of the environment should always avoid shadow areas and ensure that any operation is within the maximum levels of security in relation to its usage type.



ARCOBALENO®

## INSTALLATION & START UP

### MODEL APCG35HA

Should servicing be necessary in parts where there is not enough lighting, it is mandatory to be equipped with portable lighting systems in order to avoid shadows that prevent or reduce visibility on the place of intervention or in its surroundings.

#### 4.5 WATER SUPPLY CHARACTERISTICS

The system must be connected to a drinking water supply with the following characteristics achieved through the implementation of a water filtration/treatment system. Failure to do so automatically invalidates the guarantee.

- **Total hardness:** 0.5 to 5°F (5 - 50 mg/L calcium carbonate and magnesium) to prevent the build-up of lime-scale
- **Pressure:** 14.5 to 72.5 psi (1 - 5 bar) (100 - 500 kPa)
- **Chlorine ion concentration (Cl-):** less than 10 ppm (acceptable value) to avoid damaging the internal steel elements
- **Chloramine concentration:** must not exceed 0.02 ppm
- **pH:** over 7
- **Water conductivity:** 50 to 2000  $\mu\text{S}/\text{cm}$  (20°C) (salt can be added to increase water conductivity)
- **Sediment particulates:** not to exceed 5  $\mu\text{m}$

**IMPORTANT:** The manufacturer declines any responsibility for direct or indirect damage caused by improper or incorrect installation, alterations, maintenance or use of the appliance, as in all the other cases considered in the items of our sales conditions.

#### 4.6 WATER CONNECTION AND DRAINAGE

It is advisable to connect the appliance to the hot water pipe (max. 140°F / 60°C) to reduce heating time; it is also recommended to install a cut-off cock upstream from the appliance.

The drain piping must be connected to a suitable drain and be compliant with the norms.

The piping must be connected in such a way as to avoid contractions or siphons. Drainage of the water is free, therefore it is essential that the drain is lower than the outlet of the piping. The appliance must be installed in compliance with all local and federal regulations.

#### 4.7 CHECKING FOR CORRECT VENTILATION AND COMBUSTION AIR

1.48.1 p Ensure that the air outlets in the place of work are sufficient to guarantee the necessary air exchange, as stated in paragraph 4.3 of the UNI-CIG. norm 8723.

This appliance is intended for use only in non-combustible places.



ARCOBALENO®

## INSTALLATION & START UP

### MODEL APCG35HA

The appliance may be installed as a single element or in series with other appliances of our production. It is necessary to observe a minimum distance of 20 cm to prevent contact with walls of inflammable material; adequate measures must also be taken to ensure thermal insulation of inflammable parts, such as the installation of a protection against radiation; particular attention must be paid in installing the appliances adequately and safely. The feet are adjustable in height so that differences in level can be avoided.

The machine must be placed in conditions of optimal ventilation: the area for the combustion of the item comes captured from the bottom of the same one.

The minimal necessary area for the combustion is given from the minimal height of the feet mounted on the machine, therefore the machine cannot be installed without the adjustable feet.

#### 4.8 PIPE FOR GAS CONNECTION

The gas connection must be done with steel pipes, or otherwise with flexible steel pipes in compliance with the national norms, if any exist. Each appliance must be provided with a cut-off cock for rapid interruption of the gas supply. Once the appliance has been installed, it is necessary to check for gas leaks for the pipe fittings; do not use a flame for this purpose but a non-corrosive substance such as soapy water or foamy substances as contained in leak-finder sprays. All our appliances undergo careful testing: the type of gas, the operating pressure and the category are indicated on the data plate.

**NB:** The year of the appliance manufacture is shown in item “N” on the data plate. The first two numbers (e.g. 13...) represent the year of manufacture.

#### 4.9 CHECKING HEAT OUTPUT

The appliances must be checked in such a way as to verify that the heat output is correct:

- The heat output (thermal power) is indicated on the data plate of the appliance.
- Firstly, check that the appliance can be used with the type of gas supplied; then check that the indication on the plate corresponds to the gas to be used. For converting to another type of gas, check with manufacturer.

Check the plate, read the pressure and verify that the description of the nozzle installed corresponds to the one supplied by the manufacturer.

#### Connection for liquid gas (Propane HD-5)

Propane connection is optional, available on request. (See page 26, Section 4.17 - Liquid Propane Set Up)

#### Connection with natural gas

The normal connection pressure for natural gas is 1.74 kPa. = 7 iwc (pressure regulator inlet)



ARCOBALENO®

## INSTALLATION & START UP

### MODEL APCG35HA

The outlet pressure is read with a gauge inserted in the relative pressure outlet. Remove the hermetically closed screw and insert the gauge pipe.

**NOTE:** GAS A = Natural gas (pressure at the outlet of the regulator) = 10 mbar (4 inch water)

**NOTE:** GAS E = Propane gas (optional, on request) (See page 26, Section 4.17 - Liquid Propane Set Up)

After reading, put the screw back, tightening it hermetically and check for pressure leaks.

This appliance is equipped for natural gas.

Propane is available upon request from the manufacturer. (See page 26, Section 4.17 - Liquid Propane Set Up)

Check the plate, read the pressure and verify that the description of the nozzle installed corresponds to the one supplied by the manufacturer.

#### BURNERS TECHNICAL DATA TABLE (NATURAL GAS)

Nominal input	Reduced input	Primary air setting	Main burner injector	Pilot burner injector	By-pass screw
80185 Btu/h 23.5 kW	27980 Btu/h 8.2 kW	GAS A: open	GAS A: 3.40mm (Ø)	GAS A: 0.62 mm (Ø)	GAS A: 1.50 mm(Ø)*

\* Unscrewed for about one turn + 1/2 turn.

**NOTE:** GAS A = Natural gas (pressure at the outlet of the regulator) = 10 mbar (4 inch water)

#### 4.10 RULES FOR CONVERTING AND INSTALLING FOR OTHER TYPES OF GAS

Our appliances are tested and regulated with liquid gas (see data plate).

The conversion or adaptation to another type of gas must be approved by the manufacturer and be previously agreed upon.

#### 4.11 CHECKING FUNCTIONING

- The appliance contains the instructions necessary for use.
- Check the appliances for gas leaks.
- Examine the flame of the pilot burner; it must lap the thermocouple and be blue, otherwise examine the nozzle of the pilot burner.
- Check the lighting and flame of the main burner.
- We urge the user to follow the instructions when using the appliance.



ARCOBALENO®

## INSTALLATION & START UP

### MODEL APCG35HA

#### 4.12 INSTRUCTIONS FOR INSTALLATION

Data plate, markings and location of electrical diagrams on the appliance are on the front side, by opening the door, and has all the data necessary for the connection. The electrical diagram can also be found on page 52 of this manual.

An enlarged diagram detailing the locations of the electrical connection, gas connection, water connection, and water drainage can be found on page 44 of this manual.

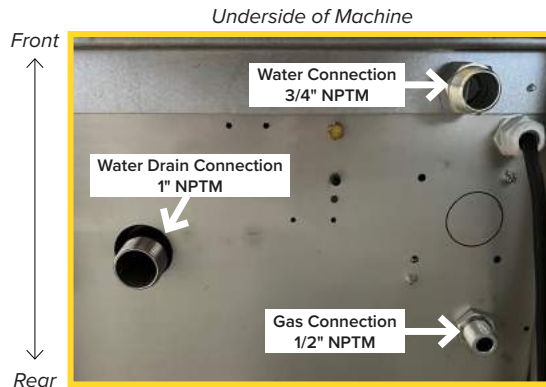
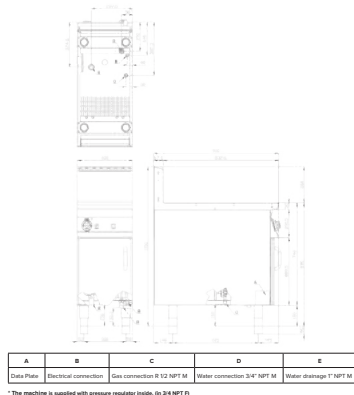

#### Installation

FOR USE IN NONCOMBUSTIBLE LOCATIONS ONLY. MINIMUM DISTANCE OF 20 CM (SIDE AND BACK) TO PREVENT CONTACT WITH WALLS OF COMBUSTIBLE MATERIAL. NO MINIMUM DISTANCE REQUIRED FROM NONCOMBUSTIBLE MATERIALS.

When fitting, the appliance must be levelled using a spirit level. Slight differences of level can be adjusted by screwing or unscrewing the adjustable feet. The main switch or the socket must be near the appliance and easily accessible.

It is advisable to place the appliance under an extractor hood so that steam is extracted rapidly. If the appliance is placed near walls, dividing panels, kitchen furniture, decorative finishing, etc., these should be in flameproof material; otherwise it is necessary to cover them with non-flammable material.

Above all, it is necessary to ensure that the fire prevention norms are observed.

The installation, starting up and maintenance of the appliance must be carried out by qualified personnel. All operations done when installing must be carried out observing the norms in force.

The manufacturer declines all responsibility in the event of incorrect functioning due to wrong installation or installation which does not comply with the norms.



ARCOBALENO®

## INSTALLATION & START UP

### MODEL APCG35HA

**ATTENTION!** In accordance with international rules, when connecting the appliance, an automatic device enabling the disconnection of all contacts from the mains, must be installed above it; this device must have a contacts opening of at least 3 mm.

#### 4.13 LAWS, TECHNICAL RULES AND NORMS

Installation must be carried out observing the following norms:

- Safety prescription in force
- Installation prescription in force

#### 4.14 ELECTRIC CONNECTION

The appliance is supplied with the connection cable and plug. The power supply for this unit should be 120V/1/60Hz. If you have any issues please consult a qualified electrician or contact the manufacturer.

DO NOT plug the machine into an extension cord, as this will introduce the plug to dangerous areas (i.e. trampling, water). **Plugging the machine into an extension cord will void the warranty.** The machine must be plugged into an outlet which complies with the norms in force in the Country in which the installation is carried out.

#### 4.15 EQUIPOTENTIAL

The appliance must be connected to an equipotential system. The connection screw is positioned at the back of the appliance and is identified by the  symbol.

**ATTENTION!** The manufacturer will neither be held responsible for, nor will give any compensation during the guarantee period for any damage caused, and which is due to inadequate installations not compliant with the instructions.

#### 4.16 INSTRUCTIONS FOR DISCHARGING GAS EMISSIONS

##### Type “A” Appliances

Type “A” appliances must discharge the products of combustion into extractor hoods or similar devices connected to an efficient chimney, or directly outside. (Natural Discharge) Fig.1.

If there is no hood, as an alternative, an air extractor connected directly to the outside is acceptable, (Forced Discharge) Fig.2, but its capacity must not be inferior to what is established.

##### In the event of forced discharge

The gas supply to the appliance, must be directly interlocked to the system and must cut off automatically if its capacity drops below the values prescribed.

Supplying the appliance with gas again must only be possible manually.



ARCOBALENO®

# INSTALLATION & START UP

## MODEL APCG35HA

NATURAL DISCHARGE Fig.1

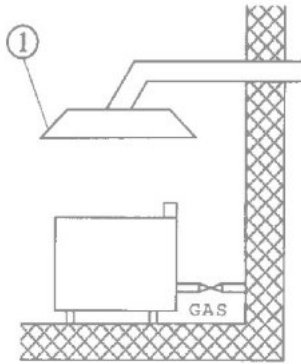

1) Extractor hood

FORCED DISCHARGE Fig.2

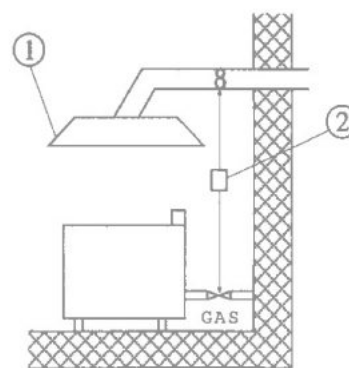
1) Extractor hood  
2) Interlocking

### Type “B11” appliance (see data plate)

#### 1) Natural Discharge (Fig.3)

Connection to a chimney with natural pull made reliably efficient by means of an anti-wind fitting and discharging the products of combustion directly outside.

#### 2) Forced Discharge (Fig.4)

The gas supply to the appliance must be directly interlocked to the system of forced discharge and must cut off automatically in the event that its capacity goes below the values prescribed by item 4.3 by the UNI-CIG norm 8723.

The release of gas to the appliance must be possible only manually.

In the event of installation, the end part of the discharge pipe of the appliance must be at least 1.8 m from the surface on which the appliance is placed (ground). The section of the discharge pipe outlet must be placed inside the perimeter.

NATURAL DISCHARGE Fig.3

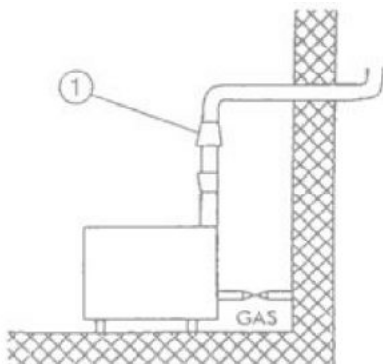

1) Anti-wind (blowback) chimney

FORCED DISCHARGE Fig.4

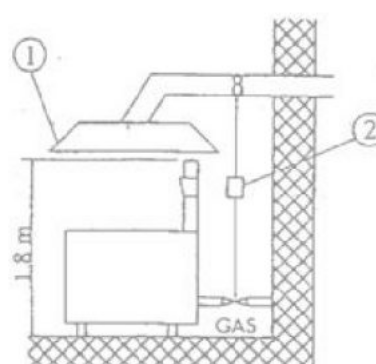
1) Extractor hood  
2) Interlocking



ARCOBALENO®

## INSTALLATION & START UP

### MODEL APCG35HA

#### 4.17 LIQUID PROPANE SET UP (OPTIONAL, UPON REQUEST)

Liquid Propane (LP) is available upon request from the manufacturer. Machines set up for LP will be noted on the machine, data plate, box, and paperwork from the manufacturer.

If the unit has been set up for LP, please refer to the following data when installing the machine. All installation guidelines previously listed must be followed, with the exception of natural gas values.

#### PRESSURE REGULATOR

The machine is supplied with pressure regulator inside. (in 3/4 NPT F)

**WARNING:** Maximum Supply Inlet Pressure = 11 iwc (Liquid Propane)  
Outlet Pressure of Regulator = 24.9 mbar (10 inch water) (Liquid Propane)

#### CHECKING HEAT OUTPUT

The appliances must be checked in such a way as to verify that the heat output is correct:

- The heat output (thermal power) is indicated on the data plate of the appliance.
- Firstly, check that the appliance can be used with the type of gas supplied; then check that the indication on the plate corresponds to the gas to be used. For converting to another type of gas, check with manufacturer.

Check the plate, read the pressure and verify that the description of the nozzle installed corresponds to the one supplied by the manufacturer.

#### Connection for liquid gas (Propane HD-5)

The normal connection pressure for liquid gas is 2.74 kPa = 11 iwc with Propane HD-5 (pressure regulator inlet)

The outlet pressure is read with a gauge inserted in the relative pressure outlet.  
Remove the hermetically closed screw and insert the gauge pipe.

**NOTE:** Propane gas (pressure at the outlet of the regulator) = 24.9 mbar (10 inch water)

After reading, put the screw back, tightening it hermetically and check for pressure leaks.

Orifices necessary for LP (propane) (natural) conversion are provided by the manufacturer.

#### BURNERS TECHNICAL DATA TABLE (LIQUID PROPANE)

Nominal input	Reduced input	Primary air setting	Main burner injector	Pilot burner injector	By-pass screw
80185 Btu/h 23.5 kW	27980 Btu/h 8.2 kW	Open	1.95mm (Ø)	0.30 mm (Ø)	1.50 mm (Ø)**

\*\* Screwed fully down.



**ARCOBALENO®**

# **USE OF THE MACHINE**

## **MODEL APCG35HA**

### **SECTION 5**

CERTIFICATION .....	28
OPERATIVENESS .....	28
CHECKING FUNCTIONING.....	28
INSTRUCTIONS FOR USE.....	29
OPERATION.....	30
FILL MODES .....	31
WATER LEVEL SELECTOR (STEAM/BOIL) .....	31
RED WARNING LIGHT.....	31
TURNING OFF THE APPLIANCE.....	31
ANOMALIES.....	32
LOCK OUT / TIME OUT MODE .....	32
EMPTYING THE TANK.....	33
TROUBLESHOOTING.....	34

**5.1 CERTIFICATION**

Before starting for the first time any operating activity, perform the checks provided for in Section 4

- Supply the electric box
- Activate any circuit by turning on the master switch

**5.2 OPERATIVENESS**

**WARNING:** A complete reading of this instruction manual and of any related attachments is necessary prior to start any operating activity. The warranty as to the working order of the machine within safety conditions and absolute performance according to its expected use, is strictly dependent on accurate application of this instruction manual and of any related attachments.

**Operator**

He/she should be a person fit for work and able to attend to any needs regarding the machine operation (see Section 3). He/she should not allow any other person to approach the area when the machine is working and should forbid its use by staff unfamiliar with such activities. He/she should follow any directions provided in this manual in order to achieve maximum performance, minimum wear and tear, and greater security for both himself/herself and others.

If your machine is not functioning properly, don't perform any operations that might compromise the good working order of the whole installation. When in doubt, always request the help of a team of specialists authorized by the manufacturer.

✓ ANY VIOLATION OR DAMAGE TO THE EQUIPMENT ON THE PART OF THE USER RELIEVES THE MANUFACTURER FROM ANY LIABILITY AND MAKES THE USER EXCLUSIVELY LIABLE FOR ACCIDENT PREVENTION TO THE COMPETENT AUTHORITY

**WARNING:** It is advisable to read any specific paragraph several times and, if in doubt, to consult the manufacturer indicating the passage whose construction seems unclear.

**5.3 CHECKING FUNCTIONING**

- The instructions necessary for use are enclosed with the appliance.
- Check the appliances for gas leaks.
- Examine the flame of the pilot burner; it must lap the thermocouple and be blue, otherwise examine the nozzle of the pilot burner.
- Check the lighting and flame of the main burner.
- We urge the user to follow the instructions when using the appliance.



ARCOBALENO®

## USE OF THE MACHINE

### MODEL APCG35HA

#### MAINTENANCE

With prolonged use of the appliance, it is essential to carry out regular maintenance for the safe functioning of the appliance.

Maintenance must only be done by specialized personnel, observing the norms in force and our indications. See Section 6 - Maintenance for more details.

**ATTENTION!** Before lighting the appliance, it must be washed with water and washing-up liquid, rinsed thoroughly and filled with water up to the level indicated by the mark on the back of the water tub.

**WARNING** DO NOT LIGHT THE PILOT WITH THE WATER TANK EMPTY.  
Damage to the tank from heating while empty will not be covered under warranty.

#### 5.4 INSTRUCTIONS FOR USE

**ATTENTION!** Use the appliance only under surveillance.

Check that the water drain valve is in the closed/off position before starting operation. The drain handle should be in the closed position (horizontal).



Horizontal = Drain Closed

**WARNING:** Never light the pilot without water in the tank.



ARCOBALENO®

## USE OF THE MACHINE

### MODEL APCG35HA







#### APCG35HA

1. Red Gas Control Knob
2. Red Warning Light
3. Ignitor Button
4. Water Fill Switch
5. Water Level Toggle Switch
6. On/Off Toggle Switch

### 5.5 OPERATION

1. Verify the drain valve handle is in the closed/off position (horizontal).
2. Toggle green on-off switch to **I / On** position.
  - The red warning light flashes once after the unit is powered on.
  - The red warning light will continue to flash until water sensor detects water.
  - Water begins to fill the tank.
3. Toggle water level switch  to the desired function (Steam or Boil). (See Water Level Selector (Steam/Boil) on next page.)
4. Before lighting the pilot, water must be in the tank.

**⚠ WARNING DO NOT LIGHT THE PILOT WITH THE WATER TANK EMPTY.**  
**Damage to the tank from heating while empty will not be covered under warranty.**

5. Push and turn the red gas control knob to the  position and hold it down.  
 At the same time, press and hold the ignitor button  for 3 seconds or until the pilot is lit.
6. Once the pilot is lit, release the ignitor button, but continue to hold the red gas control knob for an additional 45 seconds.
7. Turn the red gas control knob to the maximum burner position . Please note that the main burner will not turn on while the red warning light is active. (See Red Warning Light on next page.)
8. To set the burner to the minimum, turn red gas control knob to the  position.
9. If boil mode is selected, the tank will fill and the water will either stop or reduce to a trickle. (See Fill Modes on next page.)
10. Allow 20 minutes for water to come to a boil.



ARCOBALENO®

## USE OF THE MACHINE

### MODEL APCG35HA

#### FILL MODES

Standard (Std.) Fill Mode - blue toggle switch not illuminated

- Tank will fill quickly
- When filled, water turns off
- Water refills as needed to maintain level

Continuous (Cont.) Fill Mode - blue toggle switch illuminated

- Tank is filled quickly
- Once the tank is filled, water is reduced to a continuous trickle maintaining water level during high volume operation

#### WATER LEVEL SELECTOR (STEAM/BOIL)

Steam

- If toggled in the steam (down) position, water will fill to bottom sensor (halfway).

Boil

- If toggled in the boil (up) position, water will fill to the top water sensor (full).

#### RED WARNING LIGHT

- The red light indicates the presence of water. It will flash once after the unit is powered on.

Out = Presence of water detected

Flashing = Actively searching for water

Solid = Water not detected, turn machine off (green on-off switch) for 20 seconds to reset

**Note:** If water is present in the tank but not detected, it is necessary to turn off the machine, drain the water, and clean the water sensors with a scrub pad. The water sensors are on the front wall of the tank, which is visible when leaning over the front of the pasta cooker. Any questions, please call Arcobaleno.



Water Sensor

#### 5.6 TURNING OFF THE APPLIANCE

Push and turn the red gas control knob into the OFF position. This command blocks the gas supply to both the main burner and the pilot burner.

To relight the appliance, it is necessary to turn the knob again into the ★ position and press the ignitor button ⚡.

To turn off the machine, switch the green on-off switch to the 0 / Off position.

**NOTE:** The green on-off switch does not extinguish the pilot.

The pilot must be extinguished by turning the knob to the "OFF" position.





ARCOBALENO®

## USE OF THE MACHINE

### MODEL APCG35HA

#### 5.7 ANOMALIES

If the water sensor does not detect the presence of water, the machine will refill to the correct water level. If after 15 sec. it does not detect water, it will disable the main burner: the alarm is indicated by the red warning light flashing. Once the water sensor detects the presence of water, the red light will stop flashing and the main burner will reactivate.

**NOTE:** The filling phase is monitored by the system through the LOCK OUT/TIME OUT. (See Section 5.8)

**IMPORTANT:** Keep the water sensors clean. The water sensors are on the front wall of the tank, which is visible when leaning over the front of the pasta cooker. The water sensors can be cleaned with a scrub pad.



Water Sensor

#### 5.8 LOCK OUT / TIME OUT MODE

If filling the tank with water takes longer than 6 minutes and/or the water is not detected the unit will go into lock out mode. This is indicated by the red warning light illuminating solid red.

Events which can cause lock out mode include the drain valve being open, obstructed water sensor(s), problems with the water supply, etc.

If the machine is in lock out mode, follow these instructions to reset:

- Toggle green on-off switch to the 0 / Off position.
- Wait 20 seconds.
- Toggle green on-off switch to the I / On position.

If the red warning light continues to flash when the tank is filled with water:

- Turn the machine off by setting the red gas control knob and the green on-off toggle switch to the OFF positions.
- Drain the water.
- Clean the water sensors located on the front wall of the tank.
- Perform start up procedure to confirm machine is operational.
- Call Arcobaleno with any questions.

**IMPORTANT:** Keep the water sensors clean. The water sensors are on the front wall of the tank, which is visible when leaning over the front of the pasta cooker. The water sensors can be cleaned with a scrub pad.

**IMPORTANT:** Wastewater when discharged into the building drainage system shall be at a temperature not higher than 140°F (60°C). Discharging water over 140°F may cause damage.



ARCOBALENO®

## USE OF THE MACHINE

### MODEL APCG35HA

#### 5.9 EMPTYING THE TANK

**WARNING** **PRIOR TO DRAINING PASTA COOKER: TURN MACHINE OFF.**  
**A. Wait 10 minutes OR until water reaches 140°F (60°C) before draining.**  
**B. Add 1 gallon of cold water before draining.**  
**Failure to do so will result in machine damage and will void the warranty.**

1. Turn machine off by setting the red gas control knob and the green on-off toggle switch to the **OFF** positions.
2. Allow water to cool to 140°F (60°C). 1 gallon of cold water can be added to expedite cool down.
3. Drain water by opening the front door and rotating the drain handle from the horizontal (closed) position to the vertical (open) position.



Horizontal = Drain Closed



Vertical = Drain Open

**IMPORTANT:** Wastewater when discharged into the building drainage system shall be at a temperature not higher than 140°F (60°C). Discharging water over 140°F may cause damage.



### 5.10 TROUBLESHOOTING

Problem	Possible Cause	Solution
Water not heating up	No gas supply	Make sure all gas valves are open.
	No pilot	Follow instructions in section 5.5 to light pilot.
	Burner knob not in correct position	Turn burner knob into heating range.
	Water not detected (indicated by flashing or solid red warning light)	Turn unit off (green on-off switch) and clean the water sensors.
Pilot goes out when knob is released	Knob released too early	Once the pilot is lit, continue holding the knob in for 45 seconds, then release it.
Trouble keeping pilot lit	Dirty pilot burner	Remove pilot burner and clean.
Pilot is lit, but unable to light burner/solid red warning light	Unit not detecting water	Turn unit off (green on-off switch) and clean the water sensors.
	Pasta cooker in lock out/time out mode due to drain valve being open, obstructed water sensor(s), problems with the water supply, etc.	Resolve the issue, then turn off the machine (green on-off switch) for 20 seconds to reset.
Unit not filling with water	Drain valve open	Ensure the drain valve handle is in the closed/off position (horizontal).
Unit not filling above halfway	Steam mode selected	Toggle level selector switch to Boil position (up). (See Water Level Selector (Steam/Boil) on page 31)

If the problem persists and you cannot find a solution, turn off the gas tap and notify the Arcobaleno Service Department at 800-875-7096.



**ARCOBALENO®**

**MAINTENANCE**  
MODEL APCG35HA

**SECTION 6**

CLEANING AND MAINTENANCE..... 36  
GENERAL..... 37  
ROUTINE MAINTENANCE ..... 37  
SCHEDULED MAINTENANCE..... 37



## 6.1 CLEANING AND MAINTENANCE

**ATTENTION!** During cleaning, do not wash the external parts of the appliance with direct sprays of water or with high pressure.

After every use, clean the appliance thoroughly. Daily cleaning after switching off the appliance ensures the perfect functioning and long life of the appliance.

Before starting to clean the appliance, turn the unit off and disconnect the power supply. Make sure the unit is fully cooled before touching to avoid injury. The parts in steel must be washed with hot water and neutral detergent, then rinsed thoroughly in order to eliminate all traces of detergent; after which, dried with a dry cloth. Do not use abrasive or corrosive detergents.

The enamelled parts should be washed with soapy water.

Cleaning the tank is made easier by removing the support grill.

### **Daily Cleaning:**

- Ensure the unit is off and has returned to room temperature.
- Clean the walls of the tank with a mild detergent and non-abrasive cleaning pad.
- Ensure water sensors are free of scale and film to ensure proper operation. The water sensors can be cleaned with a scrub pad.

### **Descaling:**

- Fill tank with water adding a cup of distilled white vinegar.
- Allow to soak overnight to loosen hard water scale.
- Scrub to remove scale.
- Thoroughly rinse to neutralize the distilled white vinegar.

**IMPORTANT:** As well as ordinary cleaning and maintenance, it is advisable to have the installation checked by an installer at least once a year.

### **WHAT TO DO IN THE EVENT OF A BREAKDOWN**

Turn off the gas tap and notify the after sales service (Arcobaleno).

### **PROCEDURE TO FOLLOW IF THE APPLIANCE IS NOT GOING TO BE USED FOR SOME TIME**

Turn off the gas tap and clean the appliance as specified above.

### **MAINTENANCE (ONLY FOR QUALIFIED PERSONNEL)**

Any kind of maintenance must only be done by qualified personnel. Before carrying out maintenance, remove the plug or switch off the switch above the appliance. Empty the tank when it is full.



## 6.2 GENERAL

The maintenance plan includes routine procedures, that is operations that should be performed daily and don't need any special instruments and/or equipment; and scheduled procedures, that is operations which may involve partial disassembly and removal of safety devices.

For scheduled maintenance procedures contact only competent and experienced department maintenance staff.

**WARNING:** Prior to carrying out any maintenance procedure make sure that the equipment is deactivated from the main power.

## 6.3 ROUTINE MAINTENANCE

### Daily procedures before putting the machine into service:

Carry out a visual inspection by verifying the correct tightening/clamping of any component; perform a test on the idling machine in order to locate any faults/defects, creakings, abnormal noises, etc., and operate as deemed necessary.

**WARNING:** In case of abnormal conditions or failure of any equipment component first make sure that the instructions provided in the previous paragraphs have been followed correctly.

DON'T ever carry out rush or coarse repairs which might compromise the good working order of the machine and of any related equipment. Whenever in doubt, request servicing by specialized staff authorized by the manufacturer.

### Daily procedures to be carried out once the work shift ends:

Proceed with an accurate cleaning of the entire machine. Make sure to remove any product residual. Clean carefully by using cloths dampened with water and vinegar; don't use any type of abrasive, chemical, and/or strong detergent.

## 6.4 SCHEDULED MAINTENANCE

### Procedures carried out semi-annually:

Check the safe tightening/clamping of any element that makes up the equipment by requesting the assistance of skilled and experiences department maintenance personnel. Should any excessive wear and tear or breakage be found proceed with proper replacement.

### Procedures carried out annually:

Check the conditions of any electric components and proceed with proper replacement as deemed necessary in case of fault or wear and tear; for any operation contact skilled and experienced maintenance personnel.



ARCOBALENO®

**ADDITIONAL  
USAGE GUIDELINES**  
MODEL APCG35HA

**SECTION 7**

DURING USAGE..... 39  
UNAUTHORIZED USE ..... 40



## ADDITIONAL USAGE GUIDELINES MODEL APCG35HA

### 7.1 DURING USAGE

Expected use - precautionary standards and measures:

A correct use of the machine allows operators to fully benefit from its performance within complete safety conditions. Such potential is guaranteed only by compliance with the directions provided thereunder, therefore:

ALWAYS follow this manual's directions and instructions and, prior to start up production, verify the integrity of the machine parts.

ALWAYS observe any instructions and possible warnings marked on the machines; any warning sign displayed on the machine should always be readable.

ALWAYS assess the appropriateness of the upkeep (cleaning, etc.) both of the machine and of its main parts.

ALWAYS verify the suitability and working order of the electrical system; in particular check the connection and make sure there are no insecure or dangerous connections.

ALWAYS work under the best lighting conditions as to the whole installation and, in particular, in the application area.

Before leaving the work area, ALWAYS turn off the machine.

At any time during inspections, repairs, routine maintenance services of the machine, ALWAYS disconnect the machine and the electric box.

ALWAYS keep clean and dry the floor surrounding the machine.

At any time during operation, ALWAYS wear suitable work clothes (including individual safety devices) subject to work environment safety standards and warning signs displayed on the equipment designed to prevent possible accidents.

ALWAYS report any defect during running (suspected breakage, incorrect movements, excessive noise) to the department head and put the machine out of order by disconnecting the equipment. Use proper signs to indicate that the machine or the whole production line is out of order.

ALWAYS use the machine in a sheltered area, within a suitable operating environment as specified in this manual.

ALWAYS use original replacement parts.



## ADDITIONAL USAGE GUIDELINES MODEL APCG35HA

In case of servicing of the machine's electric system ALWAYS contact qualified and trained personnel.

In case of doubt as to the real construction of any operating procedures described in this manual, ALWAYS contact the manufacturer; don't perform any actions if the operating procedures seem unclear to you.

### **7.2 UNAUTHORIZED USE - UNEXPECTED USE - USE NOT RECOMMENDED - EXPECTED AND UNEXPECTED IMPROPER USE**

Any machine usage for unauthorized operations, its improper use and lack of service can endanger personnel safety in addition to compromising functionality and security.

The measures provided hereunder, which obviously cannot cover the whole spectrum of improper usage possibilities, represent those more "reasonably" expected and, therefore, should be considered absolutely forbidden:

NEVER use the machine under unexpected environmental conditions.

NEVER use the machine with "temporary" connections, such as temporary cables which are not insulated.

NEVER allow any unfit person to use the machine.

NEVER use the machine without wearing suitable work clothes (including individual safety devices) subject to work environment safety standards and warning signs displayed on the equipment designed to prevent accidents.

NEVER change any safety devices, remove protection measures and/or damage the equipment.

NEVER leave the machine unattended when already qualified for operating activities.

NEVER use the machine to perform different tasks from the ones it was intended to.

NEVER change functional and performance features of the machine and/or of its components in order to increase production capacity.

NEVER allow personnel unfamiliar with ongoing operations to approach the area when the machine is working.

NEVER use or service the machine under inadequate or poor lighting/visibility.

NEVER use the machine if the content of this instruction manual was not fully understood.



## **ADDITIONAL USAGE GUIDELINES**

MODEL APCG35HA

NEVER carry out any routine maintenance activity, inspections or repairs without first deactivating the machine and the whole production line.

NEVER use any replacement parts not original or not recommended by the manufacturer.

NEVER have the machine serviced by inexperienced staff.

NEVER leave the machine unattended after any service without posting the appropriate warning sign and informing the department head.



ARCOBALENO®

**SCRAPPING & DISPOSAL,  
PARTS & ELECTRICAL DIAGRAMS**  
MODEL APCG35HA

**SECTION 8**

SCRAPPING AND DISPOSAL .....43  
MACHINE AND CONNECTIONS .....44  
PARTS DIAGRAMS ..... 45  
ELECTRICAL DIAGRAM ..... 52



ARCOBALENO®

## SCRAPPING & DISPOSAL, PARTS & ELECTRICAL DIAGRAMS

MODEL APCG35HA

### 8.1 SCRAPPING AND DISPOSAL

Should the machine be scrapped, you need to arrange for disposal of its parts by taking into consideration their different nature. For the above purpose, it may be advisable to contact companies specialized in this field which, in any case, abide by the law in force in the machine installation country as to disposal of solid industrial wastes.

**WARNING:** Don't drop the machine in very busy areas as it might endanger persons lives, minors and animals in particular; the owner of the machine shall be held responsible for any claims arising in connection with the above.



ARCOBALENO®

# SCRAPPING & DISPOSAL, PARTS & ELECTRICAL DIAGRAMS MODEL APCG35HA

## 8.2 MACHINE AND CONNECTIONS

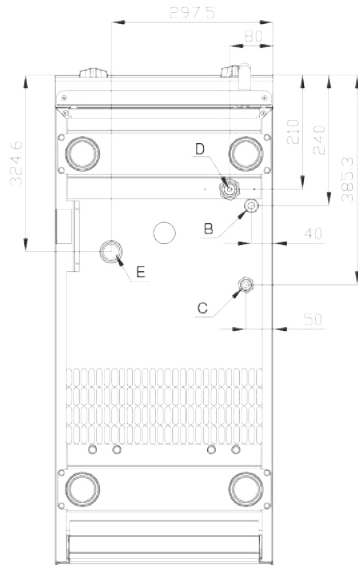

Front  
Rear

Underside of Machine

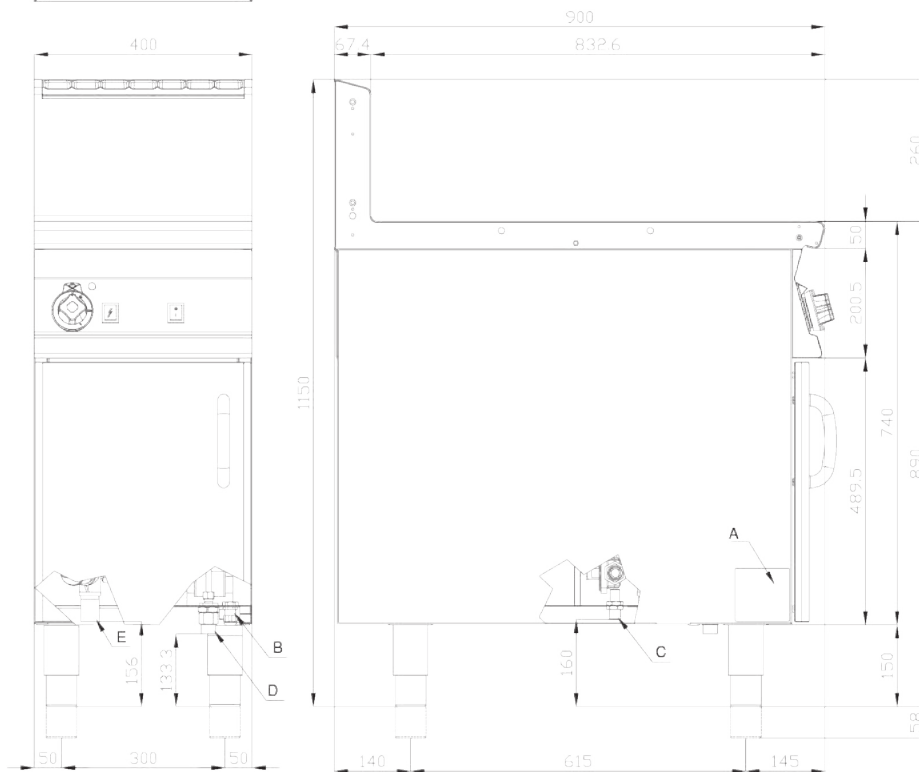
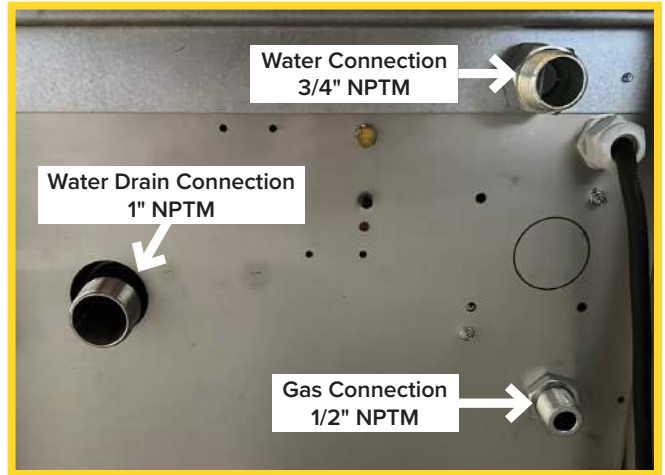

A	B	C	D	E
Data Plate	Electrical connection	Gas connection R 1/2 NPT M	Water connection 3/4" NPT M	Water drainage 1" NPT M

\* The machine is supplied with pressure regulator inside. (in 3/4 NPT F)



ARCOBALENO®

**SCRAPPING & DISPOSAL,  
PARTS & ELECTRICAL DIAGRAMS**  
MODEL APCG35HA

**8.3 PARTS DIAGRAMS**

**TABLE 1 - REMOVABLE PARTS**

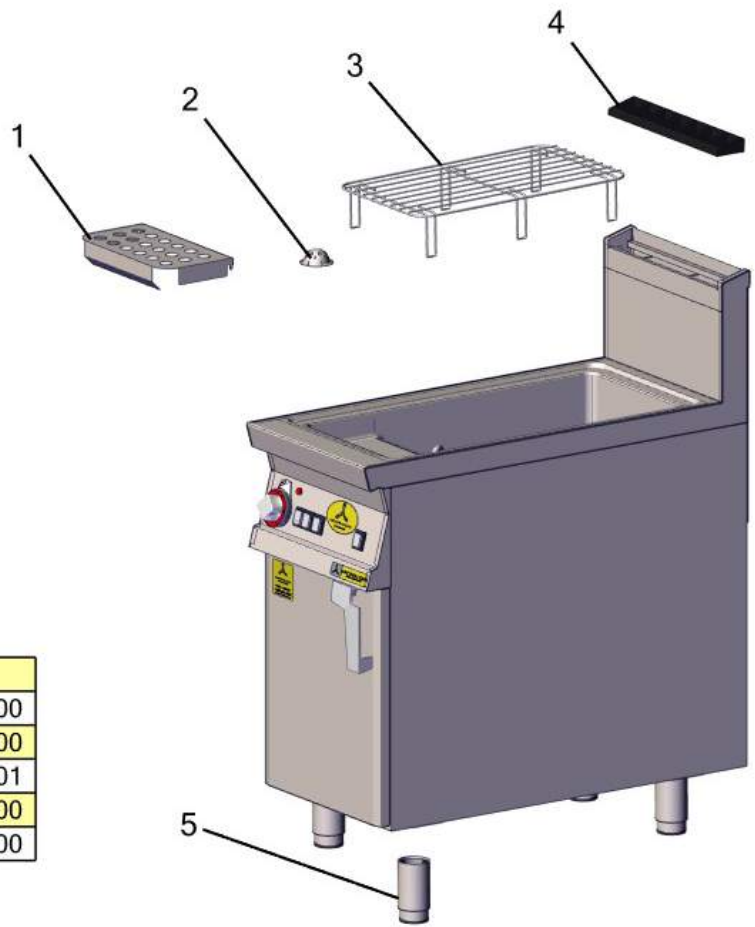

Item No.	Description	Part No.
1	Basket Holder	A544412900
2	Drain Filter	A531042800
3	Wire Basket Grate (35)	A531037701
4	Vent	A532004100
5	Adjustable Foot	A531075200



ARCOBALENO®

**SCRAPPING & DISPOSAL,  
PARTS & ELECTRICAL DIAGRAMS**  
MODEL APCG35HA

**TABLE 2 - CONTROL PANEL**

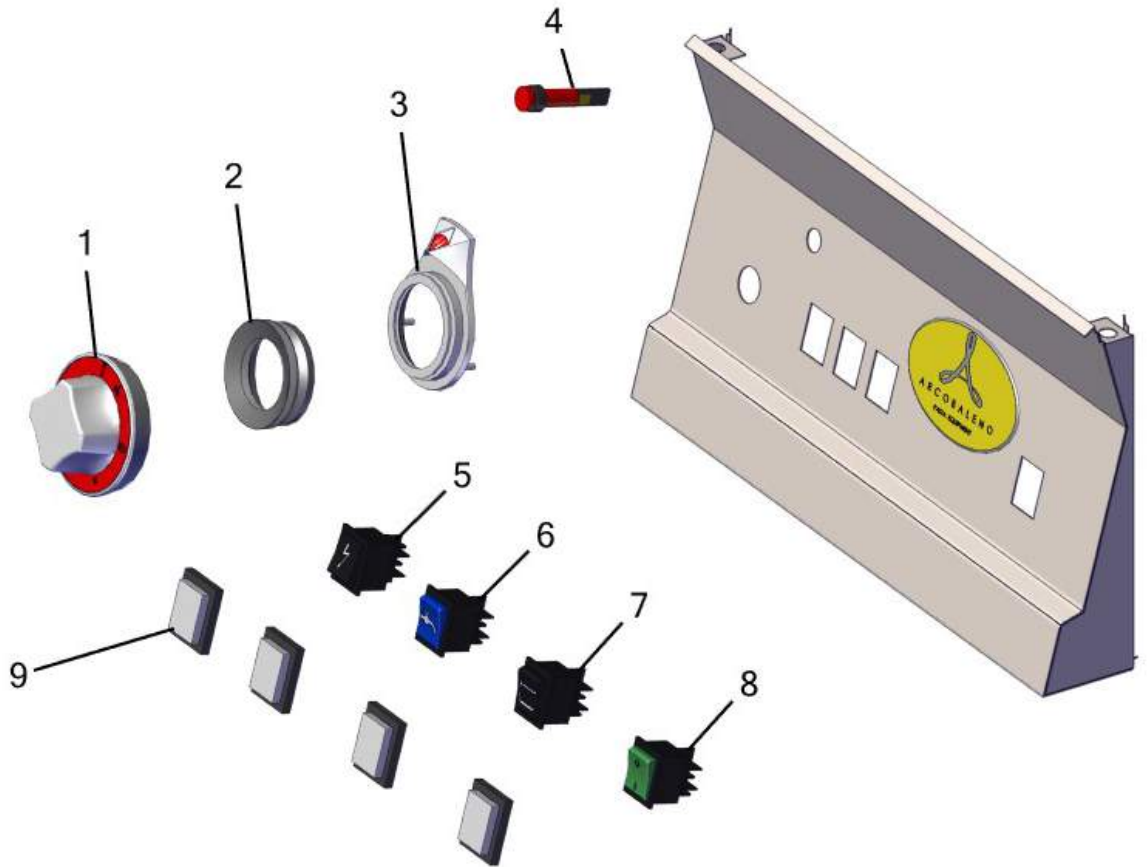

Item No.	Description	Part No.
1	High BTU Gas Control Knob	A536041900
2	Seal Casing for Knob	A536042100
3	Knob Ring	A536042300
4	Red Warning Light	A537031901
5	Ignitor Toggle Switch	A537066300

Item No.	Description	Part No.
6	Water Fill Switch (Blue)	A537059000
7	Water Level Toggle Switch (Black)	A537059100
8	Main On/Off Switch	A537058900
9	Rubber Button Cover	A536024800



ARCOBALENO®

**SCRAPPING & DISPOSAL,  
PARTS & ELECTRICAL DIAGRAMS**  
MODEL APCG35HA

**TABLE 3 - WATER LINE PARTS**

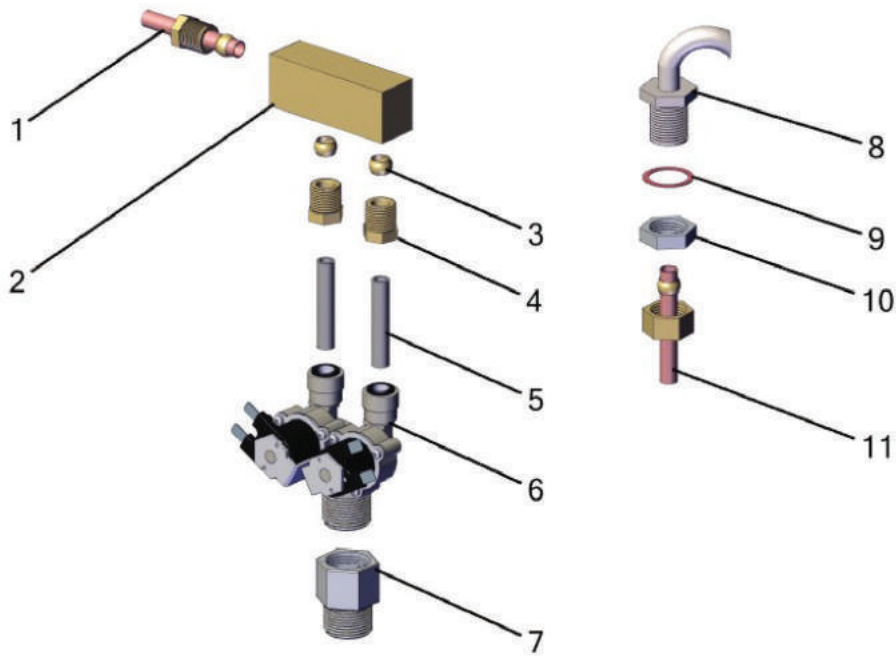

Item No.	Description	Part No.
1	Automatic Water Supply Line	A533160000
2	Water Manifold	A533159400
3	Water and Gas Line Ferrule	A533039300
4	Manifold Hex Nut	A533009500
5	Water Solenoid Valve Tubes	A544778100
6	Water Solenoid Valve Assembly	A537062901

Item No.	Description	Part No.
7	Water Line Inlet Fitting	A533075300
8	Water Spout	A531037500
9	Water Spout Sealing Ring	A533048800
10	Water Line Hex Nut	A533048700
11	Automatic Water Supply Line	A533160000



ARCOBALENO®

**SCRAPPING & DISPOSAL,  
PARTS & ELECTRICAL DIAGRAMS**  
MODEL APCG35HA

**TABLE 4 - GAS AND PILOT LINE PARTS**

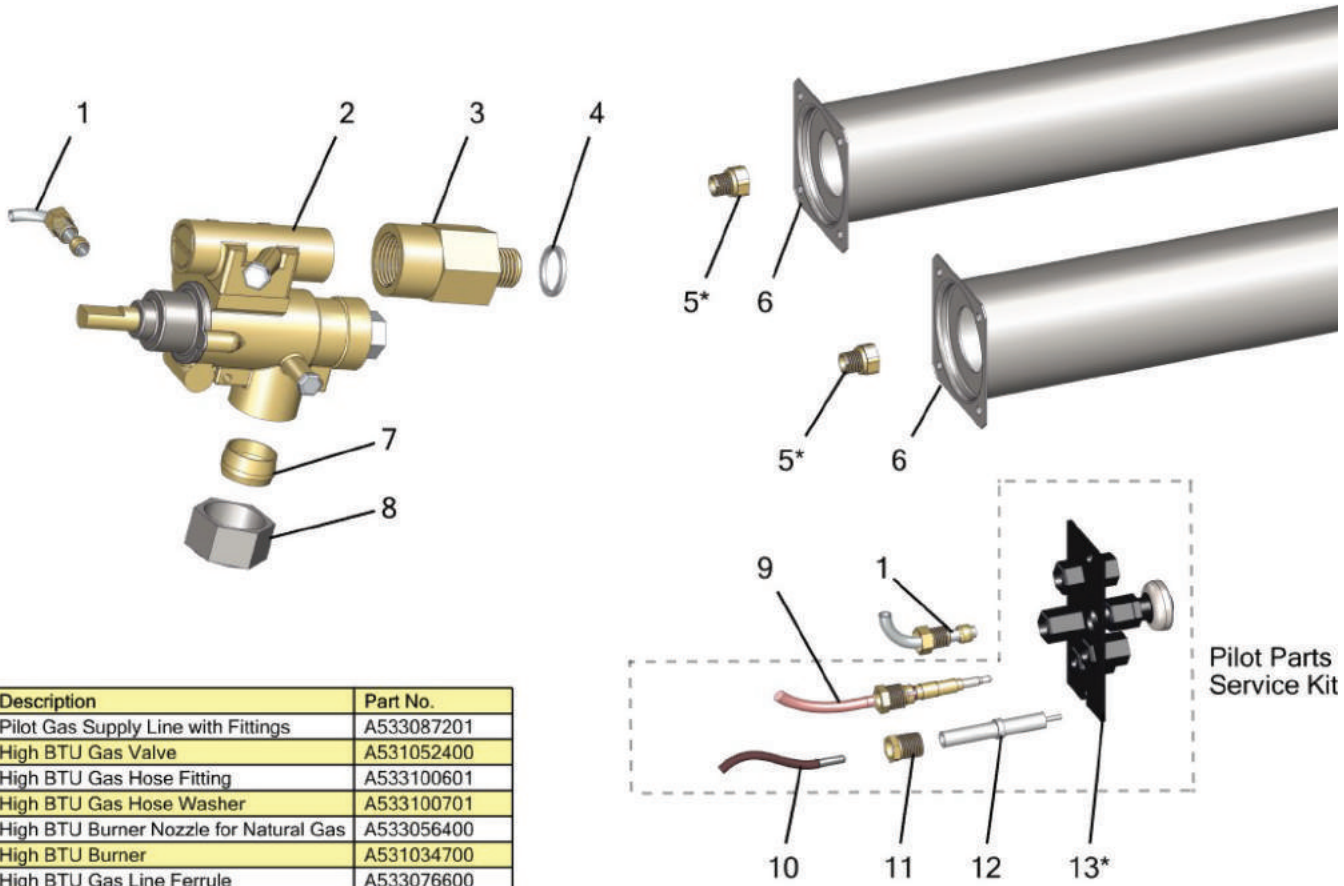

Item No.	Description	Part No.
1	Pilot Gas Supply Line with Fittings	A533087201
2	High BTU Gas Valve	A531052400
3	High BTU Gas Hose Fitting	A533100601
4	High BTU Gas Hose Washer	A533100701
5*	High BTU Burner Nozzle for Natural Gas	A533056400
6	High BTU Burner	A531034700
7	High BTU Gas Line Ferrule	A533076600
8	High BTU Gas Line Hex Nut	A533076400
9	Thermocouple	A533131400
10	Ignitor Cable	A547003200
11	Ceramic Sparker Lock Nut	A533018600
12	Pilot Ceramic Spark Ignitor	A537010200
13*	Pilot Block for Natural Gas	A533130300NG

Liquid Propane Parts		
Item No.	Description	Part No.
5*	High BTU Burner Nozzle for Liquid Propane	A533044000
13*	Pilot Block For Liquid Propane	A533130300LP



ARCOBALENO®

**SCRAPPING & DISPOSAL,  
PARTS & ELECTRICAL DIAGRAMS**  
MODEL APCG35HA

**TABLE 5 - DRAIN PARTS**

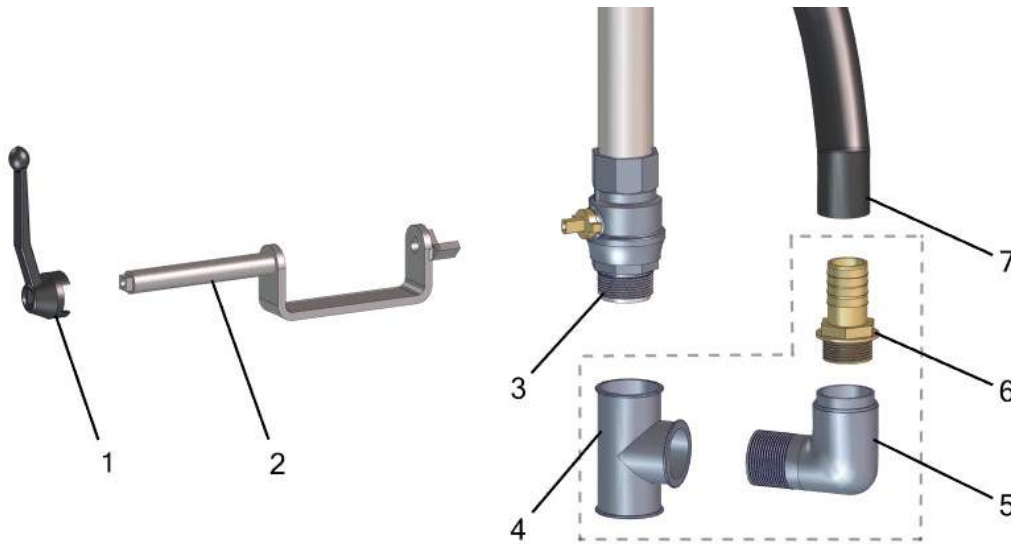

Drain Pipe and Elbow Assembly

Item No.	Description	Part No.
1	Ball Valve Handle (New Style)	A531044101
2	Handle Extension (New Style)	A533157303
3	Ball Valve (New Style)	A531044001
4	Drain Tee	A533040000
5	Drain Elbow	A533157500
6	Barbed Drain Hose Fitting	A533039900
7	Overflow Drain Hose	A546006100
8	Ball Valve Handle (Old Style)	A531044100
9	Handle Extension (Old Style)	A533157300
10	Ball Valve (Old Style)	A531018600

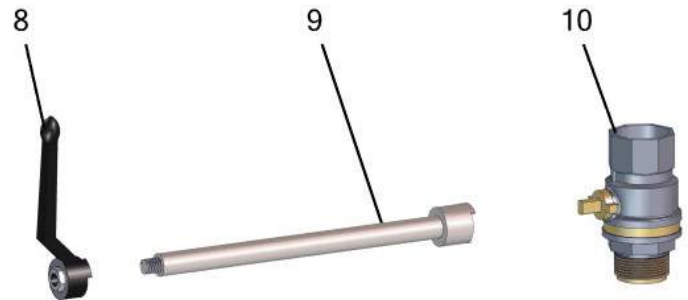



ARCOBALENO®

**SCRAPPING & DISPOSAL,  
PARTS & ELECTRICAL DIAGRAMS**  
MODEL APCG35HA

**TABLE 6 - ELECTRONICS**

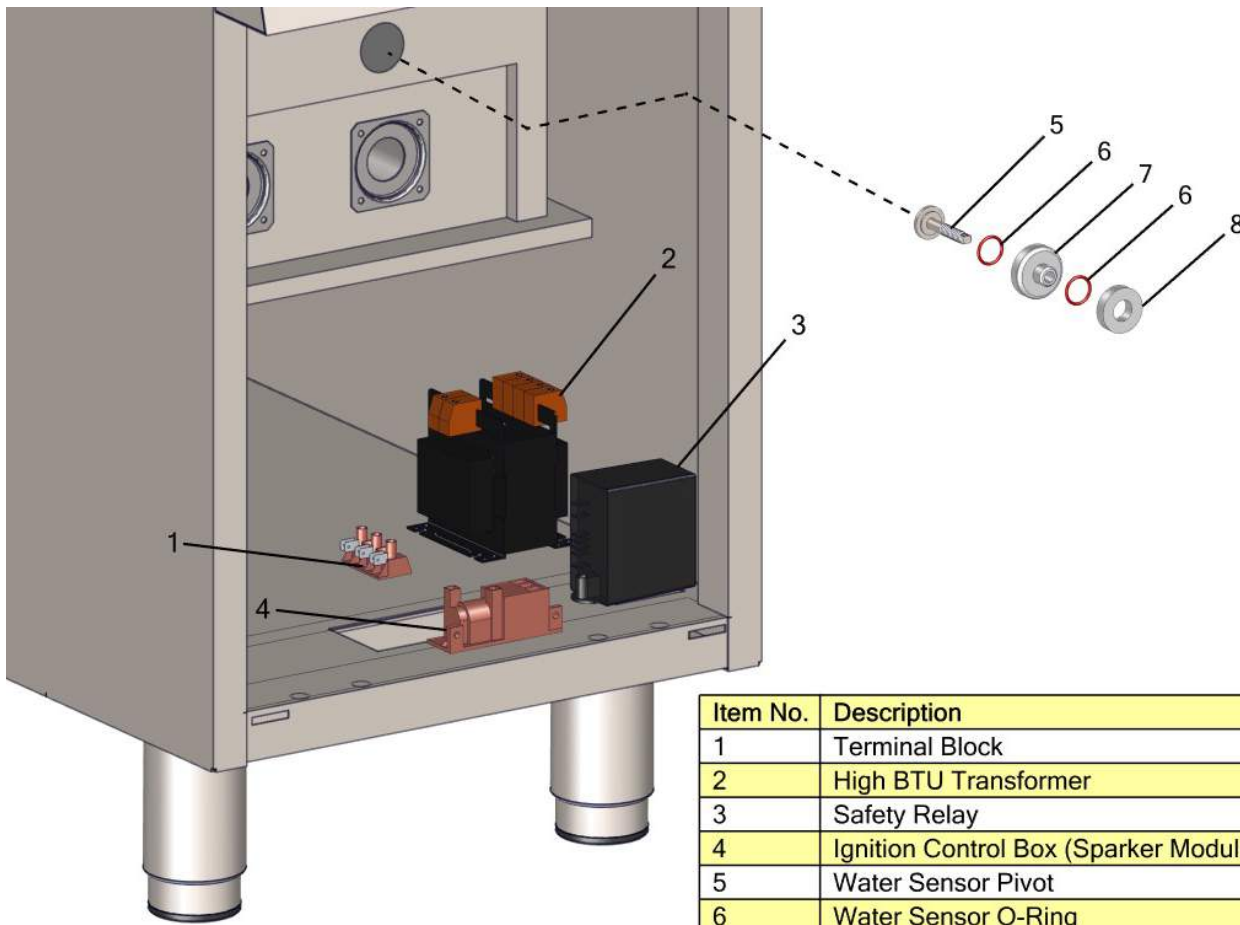

Item No.	Description	Part No.
1	Terminal Block	A537003800
2	High BTU Transformer	A537054401
3	Safety Relay	A537062800
4	Ignition Control Box (Sparker Module)	A537060301
5	Water Sensor Pivot	A533155600
6	Water Sensor O-Ring	A536039000
7	Water Sensor Guide	A536039100
8	Water Sensor Spacer	A536039200



ARCOBALENO®

**SCRAPPING & DISPOSAL,  
PARTS & ELECTRICAL DIAGRAMS**  
MODEL APCG35HA

**TABLE 7 - MAIN GAS LINE PARTS**

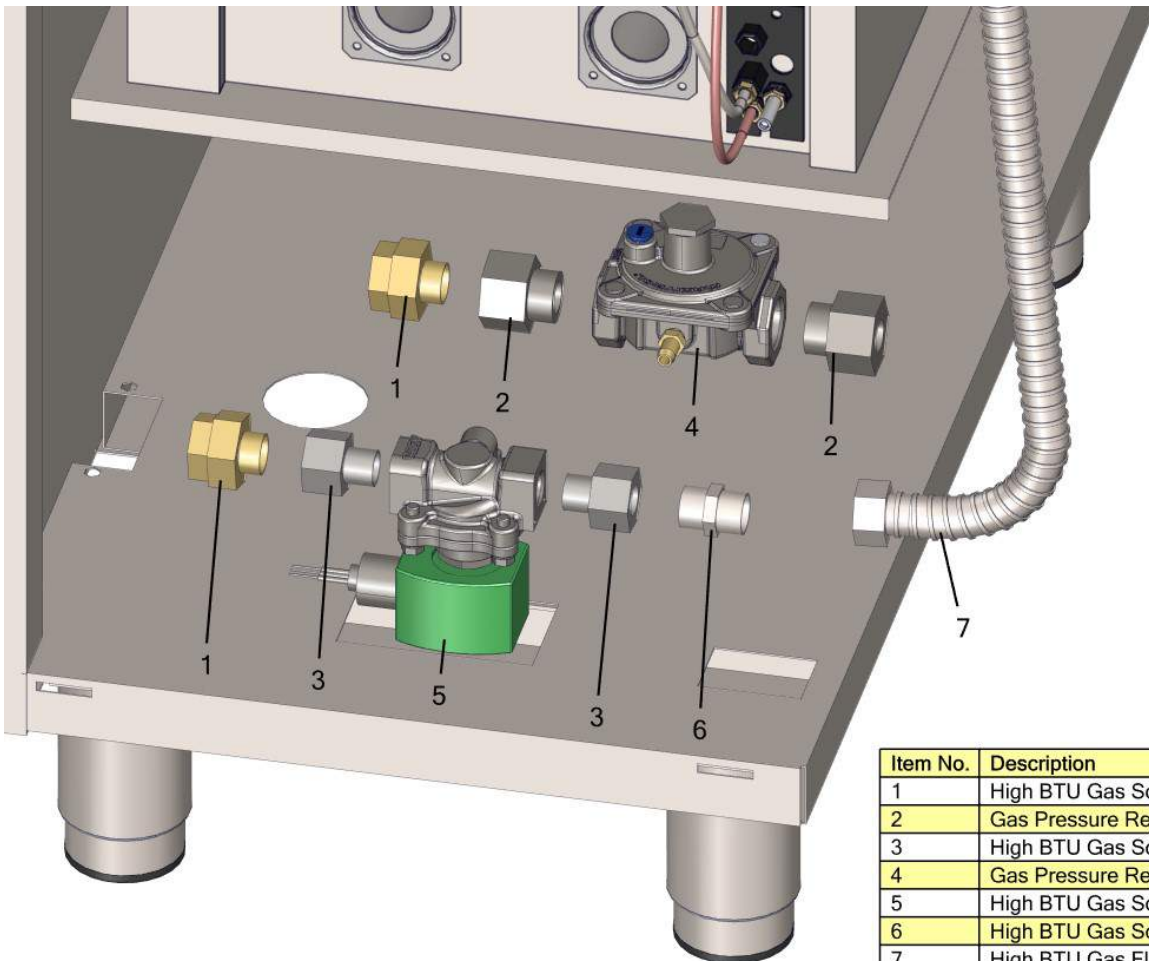

Item No.	Description	Part No.
1	High BTU Gas Solenoid Fitting 1	A531078000
2	Gas Pressure Regulator Fitting	A533075300
3	High BTU Gas Solenoid Fitting 2	A533181900
4	Gas Pressure Regulator	A531063801
5	High BTU Gas Solenoid Valve	A537067300
6	High BTU Gas Solenoid Fitting 3	A533156900
7	High BTU Gas Flex Hose	A541305400



**SCRAPPING & DISPOSAL,  
PARTS & ELECTRICAL DIAGRAMS**  
MODEL APCG35HA

**8.4 ELECTRICAL DIAGRAM**

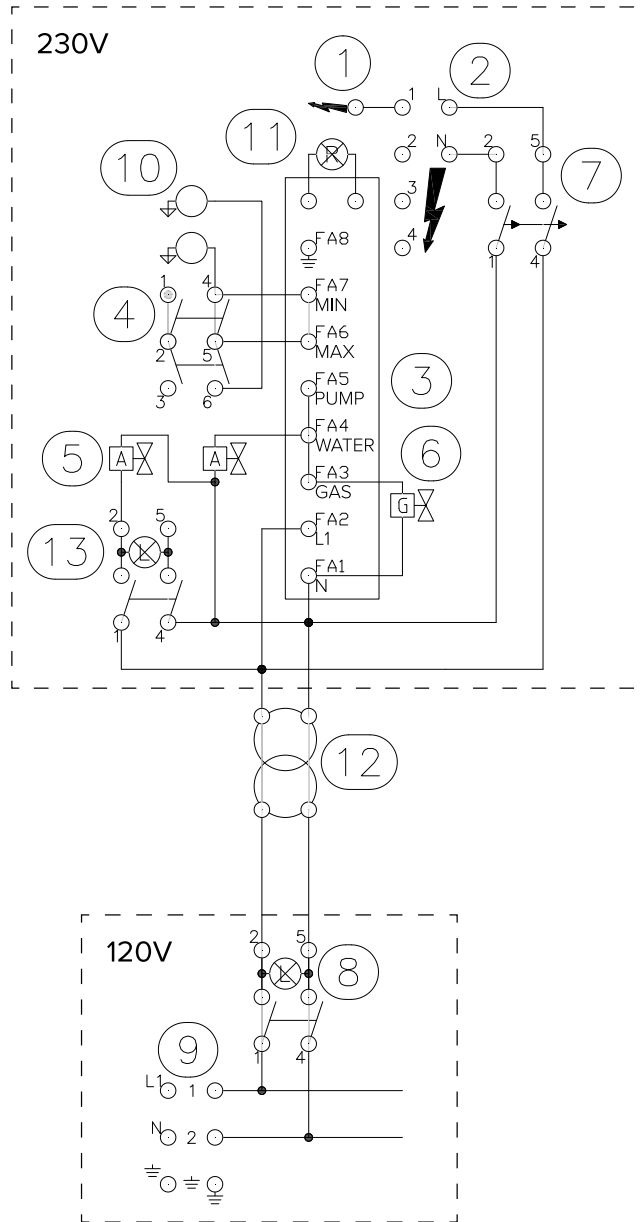

120V ~ 50/60 Hz

**APCG35HA**

<b>1</b>	Pilot Ceramic Spark Ignitor
<b>2</b>	Ignition Control Box
<b>3</b>	Safety Relay
<b>4</b>	Toggle Switch - Level Selector
<b>5</b>	Water Solenoid Valve

<b>6</b>	Gas Solenoid Valve
<b>7</b>	Toggle Switch - Ignitor
<b>8</b>	Toggle Switch - Power
<b>9</b>	Power Terminal Block
<b>10</b>	Level Probe (Water Sensors)

<b>11</b>	Red Warning Light
<b>12</b>	Step Up Transformer 120V Input 230V Output
<b>13</b>	Toggle Switch - Fill Mode