

EXTRUDER + MIXER | COUNTER TOP

MODEL AEX20 MAKING PASTA HAPPEN

SAME SIZE DIE AS AEX18!



EMMA

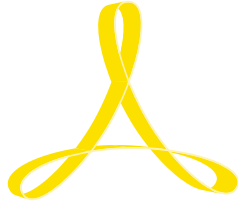

ARCOBALENO®
PASTA MACHINES

STANDARD FEATURES

- Mixer and extruder– all-in-one process
- **Over 200 dies to choose from - Same size as AEX18!**
- Includes automatic cutting knife for short pastas
- Water cooling feature to help maintain a constant extrusion temperature
- Industrial, high-torque motor
- Stainless steel hopper
- Digital display with touch screen controls for ease of use
- Removable stainless steel mixer shaft & auger for easy cleaning
- Crumbly dough mixture is extruded through a solid brass die to create over 200 possible pasta shapes
- Portable, compact & versatile machine is easy-to-use
- 110 Volts
- Factory and on-location training. The Only Full-Service Pasta Machine Manufacturer in North America!



CUTTING KNIFE FOR SHORT PASTAS

TOUCH SCREEN CONTROLS

OPTIONAL FEATURES & ACCESSORIES

- Pasta trays - Perforated - Dim: 15.5"W x 23.5"D x 2.75"H
- Pasta trays - Solid - Dim: 15.5"W x 23.5"D x 2.75"H
- APC7 Mobile pasta cart with 7 trays
- APC20 Mobile pasta cart with 20 trays
- Cooling water tank with recirculating pump
- Lasagna sheet die with 6.25" dough sheet width and Adjustable Thickness: 1/32" - 3/16"
- Rolling pin for lasagna sheet die
- Busiate die with manual crank handle
- Automatic crank attachment for busiate die
- Extruder dies with Teflon inserts



Optional
APC7 Pasta Cart



LASAGNA SHEET DIE (#60s)
SAME SIZE AS AEX18



©2026 Arcobaleno® Pasta Machines, LLC

CAD file available. Please contact factory 717-394-1402.

ARCOBALENO PASTA MACHINES, LLC
160 GREENFIELD ROAD | LANCASTER, PA 17601
ARCOBALENOPASTA.COM | 717.394.1402

@ARCOBALENOPASTA



EXTRUDER & MIXER | COUNTER TOP MODEL AEX20

ARCOBALENO®

TECHNICAL SPECIFICATIONS

Model	AEX20 - Same size dies as AEX18!
Hourly Production*	Up to 20 lbs/hr *Production varies by pasta shape
Mixer Capacity (flour)	2,500 g (5.5 lbs)
Mixer Production (flour + liquid)	3,250 g/batch (7 lbs/batch)
Electrical Power	120V/1/60Hz 10 Amps
Machine Dimensions	14.5"W x 29.25"D x 20.5"H (with knife)
Shipping Dimensions	23.75"W x 31.5"D x 31.5"H
Machine Weight	88 lbs
Shipping Weight	110 lbs
Shipping Class	125



**Same size dies
as AEX18!**

PAYS FOR ITSELF IN 30 DAYS!

AEX20 ROI BREAKDOWN



50 LB BAG OF SEMOLINA FLOUR = \$40



YIELDS 65 LBS OF FRESH PASTA



MAKES 130 - 8 OZ SERVINGS

ONLY \$0.31 PER 8 oz SERVING!

AEX20 Production



AEX20 PRODUCES 7 LBS (112 OZ) PER BATCH



MAKES 14 8 OZ SERVINGS PER BATCH

Pay Off - 30 Days

\$15-18

AVERAGE COST OF 8 OZ PASTA DISH

20

20 PASTA DISHES SOLD PER DAY = \$300-360

ROI calculations are examples for illustrative purposes only and actual costs may vary therefore; Arcobaleno, LLC cannot promise or guarantee the ROI benefits.

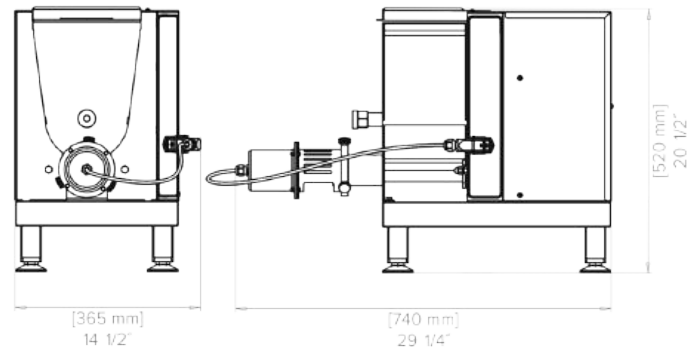

FLOUR+WATER RECIPE FOR AEX20 (30% Hydration)

2,500 grams of flour
750 grams of cold water

Additional water (25-50g) may be required.

Recipe may vary based on flour type, eggs, relative humidity, & environment. Please adjust accordingly.

WHOLE EGG RECIPE FOR AEX20 (32% Hydration)

2,500 grams of flour
8 whole eggs (Approximately 50 grams per egg)*
400 grams of cold water

** Egg size may vary. Please adjust accordingly.*

Eggs + Water must be whisked together before adding to flour.



DIRECTIONS FOR AEX20 RECIPES:

Weigh out flour and liquid required for the batch. If applicable, mix cold water and eggs together with whisk. Put flour in hopper and set mix time to 4-6 minutes. Turn on mix mode. Slowly add liquid, moving the container back and forth along the opening. Mix for 4-6 minutes. Stop machine and check consistency of contents, dough should resemble a coarse crumbly flour texture like streusel. If you do not see a coarse crumbly flour texture, drizzle an additional 25-50g of water while in mix mode for 60 seconds. The consistency of the egg pasta dough should look like small pebble sized dough balls. Set desired extrusion time. If no time is set, the timer will begin counting up once extrusion is started. Begin to extrude. Never extrude dry flour.











RECIPE!

EXTRUDED PASTA SHAPES

FOR MODEL AEX20 EMMA

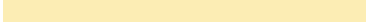
 = New Dies  = Favorite Dies  = Hand Cut Only
 Sizes measured from pasta dies, pasta size may vary slightly. Images are not to scale.





SPAGHETTI

-  ● #7 1.5 mm
-  ● #8 1.7 mm 
-  ● #9 1.9 mm
-  ● #10 2.1 mm 
-  ● #11 2.3 mm
-  ● #12 2.5 mm
-  ▲ #410 3 mm 





BIGOLI

-  ● #13 3 mm
-  ● #14 3.5 mm 
-  ● #15 4 mm

LINGUINE

-  ● #21 3 x 1.6 mm
-  ● #21A 3.5 x 1.6 mm 
-  ● #22 4 x 1.6 mm 

SPAGHETTI/ALLA CHITARRA/ TONNARELLI

-  ■ #23 1.5 mm
-  ■ #24 2 mm 
-  ■ #26 2.5 mm
-  ■ #27 3 mm



Teflon dies are available for smooth texture and used for Gluten Free and Non Traditional Recipes. Our #23 Teflon and #24 Teflon dies can be used to make ramen. *Call for more information!*







#410 Triangle Spaghetti



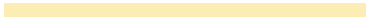

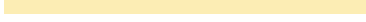
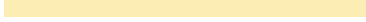

#414 Pizzoccheri

TAGLIATELLE

-  ■ #30 1.8 mm
-  ■ #31 2.5 mm
-  ■ #32 3.5 mm
-  ■ #33 4.5 mm
-  ■ #34 6 mm 

FETTUCCINE

-  ■ #35 8 mm 
-  ■ #36 10 mm
-  ■ #414 Pizzoccheri  8 x 1.8 mm

PAPPARDELLE

-  ■ #37 12 mm
-  ■ #38 15 mm 
-  ■ #38/02 17 mm
-  ■ #39 20 mm 
-  ■ #40 25 mm (1 inch) 
-  ■ #463 17 mm  [with ridges]

EXTRUDED PASTA SHAPES

FOR MODEL AEX20 EMMA

MAFALDE



#50
8.5 mm



#54
10 mm



#51
12 mm



#55
12 mm



#52
17 mm



#56
16 mm



#275
14 mm



#57
20 mm

BUCATINI/PERCIATELLI



#60 2.5 mm



#61 3 mm



#62 4 mm



#62A 5 mm



#63 6 mm



#75 4.8 mm
[with ridges]



#71 6 mm
[2 mm wall thickness]



#72 6.5 mm
[1.4 mm wall thickness]



#402 8 mm **new**
Gargati Veneti
[1.5 mm wall thickness]
[with ridges]



#426 5.5 mm **new**



#427 5.5 mm **new**
[with ridges]



#429 3.2 mm **new**

ZITI/PACCHERI



#64 8 mm



#65 9.5 mm



#66 12 mm



#67 15 mm



#67/02 17 mm



#68 20 mm



#69 25 mm



#70 25 mm
[1.4 mm wall thickness]

ARCOBALENO[®]
PASTA MACHINES

MM to INCHES Conversion Chart



Dime =
17mm (11/16")



Penny =
19mm (3/4")



Nickel =
21mm (7/8")





Quarter =
24mm (15/16")

MM	Approx. Size in Inches
1mm	1/32"
2mm	1/16"
3mm	3/32"
4mm	1/8"
5mm	3/16"
6mm	slightly less than 1/4"
7mm	slightly more than 1/4"
8mm	5/16"
9mm	slightly less than 3/8"
10mm	slightly more than 3/8"
11mm	7/16"
12mm	slightly less than 1/2"
13mm	slightly more than 1/2"
14mm	9/16"
15mm	slightly less than 5/8"
16mm	5/8"
17mm	slightly less than 11/16"
18mm	slightly less than 3/4"
19mm	slightly more than 3/4"
20mm	slightly less than 13/16"
21mm	slightly more than 13/16"
22mm	slightly less than 7/8"
23mm	slightly more than 7/8"
24mm	15/16"
25mm	about 1"
26mm	about 1 1/32"
27mm	about 1 1/16"
28mm	about 1 1/8"
29mm	about 1 5/32"
30mm	about 1 3/16"
31mm	about 1 7/32"
32mm	slightly more than 1 1/4"
33mm	about 1 5/16"
34mm	about 1 1/32"

EXTRUDED PASTA SHAPES

FOR MODEL AEX20 EMMA

 = New Dies  = Favorite Dies  = Hand Cut Only
 Sizes measured from pasta dies, pasta size may vary slightly. Images are not to scale.

RIGATONI



#73 12 mm



#73/02 13 mm



#73/04 11 mm



#76 6 mm
[with ridges]



#77 8 mm
[with ridges]



#78 10 mm 
[with ridges]



#79 12 mm 
[with ridges]



#80 15 mm 
[with ridges]



#81 18.5 mm 
[with ridges]



#82 25 mm 
[with ridges]



#83 26.5 mm 
[1.4 mm wall thickness]
[with ridges]



#84 23 mm 
[1.3 mm wall thickness]
[with ridges]



#85 10.5 mm
[1.05 mm wall thickness]
[with ridges]



#86 13.5 mm 
[1.2 mm wall thickness]
[with ridges]





#87 17.5 mm 
[1.2 mm wall thickness]
[with ridges]





#386 10 mm
Trenne
[with ridges]



#386/15L  
Trenne



#386/15R  
Trenne
[with ridges]





#264 11.4 mm
Smooth Trenne





#392 10mm
Square Rigatoni
[with ridges]



#392/15L  
Square Rigatoni





#392/15R  
Square Rigatoni
[with ridges]





#462 11.2 mm W 
Little Heart-atonì
[with ridges]



#533L 19 mm W  
Heart-atonì





#533RO 19mm W  
Heart-atonì
[with ridges]



EXTRUDED PASTA SHAPES

FOR MODEL AEX20 EMMA

 = New Dies  = Favorite Dies  = Hand Cut Only
 Sizes measured from pasta dies, pasta size may vary slightly. Images are not to scale.

ELICOIDALI

Reversed Ridges





#110 9 mm
[with ridges]



#112 13 mm
[with ridges]



#416 18 mm  
[with ridges]



GRAMIGNE



#91 3 mm



#92 4 mm 



#93 3.8 mm
[with ridges]

CANESTRI/LUMACHE [SMOOTH]



#94
7.8 mm



#95
9.8 mm



#96
12.5 mm



#97
15 mm

CANESTRI/LUMACHE [WITH RIDGES]



#99 8.6 mm



#100 10.5 mm



#101 13.5 mm 



#102 16 mm



#438 26 mm 

MACARONI [SMOOTH]



#120
3.2 mm



#121
4.2 mm



#122
6 mm



#123
7.8 mm



#124 
9.8 mm



#125
12.5 mm



#126
15 mm

MACARONI [WITH RIDGES]



#133
10.5 mm



#134
14 mm





DID YOU KNOW?

Teflon dies are available for smooth texture and used for Gluten Free and Non Traditional Recipes. Call for more information!

EXTRUDED PASTA SHAPES

FOR MODEL AEX20 EMMA

 = New Dies  = Favorite Dies  = Hand Cut Only
 Sizes measured from pasta dies, pasta size may vary slightly. Images are not to scale.

CRESTE DI GALLO



SHELLS [SMOOTH]

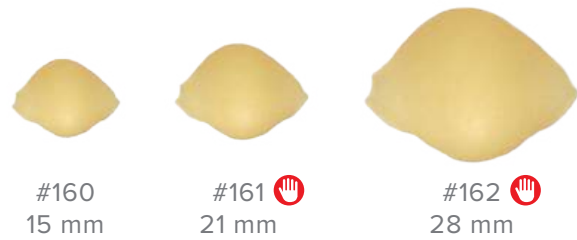

SHELLS [WITH RIDGES]



ORECCHIETTE



GNOCCHI SARDI



CLAM SHELLS [SMOOTH]

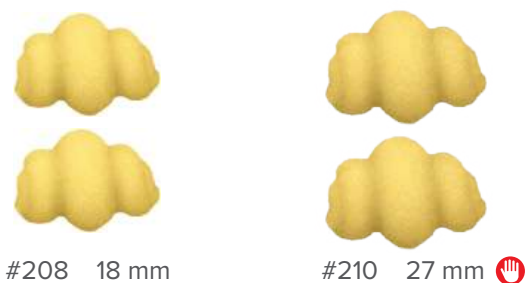

CLAM SHELLS [WITH RIDGES]



EXTRUDED PASTA SHAPES

FOR MODEL AEX20 EMMA

 = New Dies  = Favorite Dies  = Hand Cut Only

Sizes measured from pasta dies, pasta size may vary slightly. Images are not to scale.

GEMELLI

CASARECCE

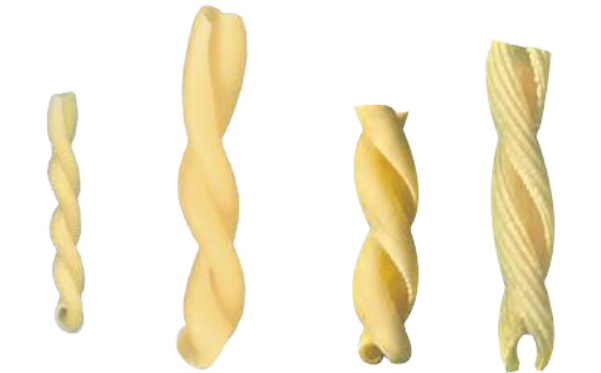

#214 6.4 mm
#215  8.8 mm
#216 14.2 mm
#225 14.2 mm [with ridges]



#219 7.8 mm
#220  8.8 mm
#221 12 mm
#227 12 mm [with ridges]
#368  10.5 mm [with ridges]
#420  6.5 mm



FUSILLI



#222 9 mm [4P]
#223 9 mm [4P]
#224 13 mm [4P]
#230 7 mm [2P]
#231 9.5 mm [2P]
#232 11.2 mm [2P]
#233 13 mm [2P] [with ridges]
#234 15.5 mm [2P]
#239 6.5 mm [3P]
#240 8.4 mm [3P]
#241  10 mm [3P]
#242 15.5 mm [2P]
#243 13 mm [3P]
#244 12.6 mm [2P]
#246 10.5 mm [3P]
#366 17 mm [3P]
#380 17.4 mm [2P]
#406   20 mm [2P]
#454 13 mm [3P] [with ridges]
#458  10 mm [3P] [with ridges]

EXTRUDED PASTA SHAPES

FOR MODEL AEX20 EMMA



 = New Dies  = Favorite Dies  = Hand Cut Only
 Sizes measured from pasta dies, pasta size may vary slightly. Images are not to scale.

SHAPES ON SHAPES ON SHAPES

 <p>#251 10.4 mm Trottole</p>	   <p>#249 11.4 mm Campanelle [with ridges]</p>	 <p>#252 11.4 mm  Campanelle</p>	 <p>#253 28 mm  Londa</p>	 <p>#404 16.5 mm  Londa</p>
 <p>#254 11 mm Torchietti [with ridges]</p>	 <p>#256 18 mm  Pretzel</p>	 <p>#258 12.5 mm Specialty 3-Loop</p>	 <p>#260 18.5 mm  Radiator </p>	 <p>#261 25 mm  Radiator</p>
 <p>#262A 13.5 mm  Anellini</p>	 <p>#262B 19 mm  Bumbola</p>	 <p>#270 16.5 mm  Rotelle (Wagon Wheel)</p>	 <p>#463 17 mm  Pappardelle [with ridges]</p>	
 <p>#264 11.4 mm Smooth Trenne</p>	 <p>#386 10 mm Trenne [with ridges]</p>	 <p>#386/15L   Trenne</p>	 <p>#386/15R   Trenne [with ridges]</p>	 <p>#392 10mm Square Rigatoni [with ridges]</p>
 <p>#392/15L   Square Rigatoni</p>	 <p>#392/15R   Square Rigatoni [with ridges]</p>	 <p>#462 11.2 mm W  Little Heart-atoni [with ridges]</p>	 <p>#533L 19 mm W   Heart-atoni</p>	 <p>#533RO 19 mm W   Heart-atoni [with ridges]</p>

EXTRUDED PASTA SHAPES

FOR MODEL AEX20 EMMA

 = New Dies  = Favorite Dies  = Hand Cut Only
 Sizes measured from pasta dies, pasta size may vary slightly. Images are not to scale.



#267 8.3 mm 
 Garganelli
 [with ridges]



#459 11.2 mm 
 Garganello
 [with ridges]



#268 6.6 mm
 Messinesi



#425 5.8 mm 
 Calabreselli



#273 6.5 mm
 Torchietto
 [with ridges]



#274 14 mm 
 Creste di Bruco



#362 10 mm 
 Rustic Torchio
 [with ridges]



#369 25 mm 
 Calamarata



#370 18 mm 
 Girelle



#275 14 mm 
 Mafalde Bucatini





#368 10.5 mm 
 Rustic Casarecce
 [with ridges]



#366 17 mm
 Large Rustic Fusilloni
 [3P]



#406 20 mm  
 Fusilloni
 [2P]



#454 13 mm
 Fusilloni
 [3P]
 [with ridges]





#458 10 mm 
 Rustic Fusilli
 [3P]
 [with ridges]



#372 8.8 mm
 Maccheroncelli



#374 22.5 mm  
 Zucca





#408 17 mm 
 Zucca



#378 11.8 mm
 Stella

EXTRUDED PASTA SHAPES

FOR MODEL AEX20 EMMA

 = New Dies  = Favorite Dies  = Hand Cut Only
 Sizes measured from pasta dies, pasta size may vary slightly. Images are not to scale.



#380 17.4 mm
Treccioni
[2P]



#384 25 mm 
Caramelle



#388 31 mm 
Clam Shell
[with ridges]



#398 15 mm 
Fiori



#390 8.6 mm 
Spaccatelli



#394 18 mm 
Sicilian 5 Buchi



#399 8.8 mm
Trifoglio



#402 8 mm 
Gargati Veneti
[1.5 mm wall thickness]
[with ridges]



#438 26 mm 
Canestri/Lumache
[with ridges]



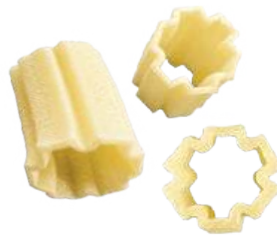

#448 24 mm 
Sunshine



#456 17 mm 
Maccherone Greco



#2023 24 mm W  
Bowtie Farfalle



SOME OF OUR FUN SHAPES



#509C 
Star



#509D 
Shooting Star



#513 
Heart



#515 
Tennis Racket



#517 
Mushroom



#529/02 
Bat



#529/04 
Pumpkin



#549 
Pumpkin



#529/06 
Spider



#529/08 
Ghost



#559 
Dollar Sign





#509B 
Tree



#580 
Grapes





#601 24mm H  
Four Leaf Clover



#644 23.5 mm H  
Flower

EXTRUDED PASTA SHAPES

FOR MODEL AEX20 EMMA

 = New Dies  = Favorite Dies  = Hand Cut Only
 Sizes measured from pasta dies, pasta size may vary slightly. Images are not to scale.

LASAGNA SHEET DIE



#60s 

Lasagna Sheet Die
with Adjustable Thickness

Dough Width: 6.25"
Adjustable Thickness: 0" - 1/8"



Lasagna Recipe:

Use 33-34% hydration. Mix for 6 min, then extrude.

Lasagna sheet thickness is adjustable to suit your preference. We recommend around 1/16" thickness for baked lasagna... no pre-cooking needed!

BUSIATE DIE

#428 
Busiate



Supplied with
Manual Crank Handle



Optional
Automatic Crank Attachment

CUSTOM SHAPES

Contact us for more information.

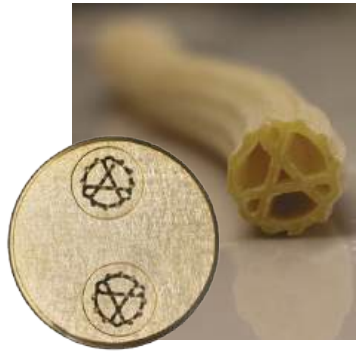

PASTA CARTS & TRAYS

STANDARD FEATURES

- APC7 and APC8 ideal for models AEX18 & AEX30 (Standard counter top height)
- Pasta Carts are NSF approved

APC7 PASTA ON THE MOVE

CARTINA



APC8 PASTA ON THE MOVE

CATERINA



APC20 TOWER OF PISA

MARTINA



APTP PERFORATED PASTA TRAY



APTS SOLID PASTA TRAY



PASTA DRYER

EXTENDS SHELF LIFE OF PASTA

ASD20 - LAB ARTISAN SMALL BATCH LAB DRYER

MONICA

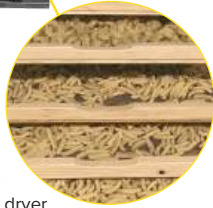

ASD50/75/100/150/200 EXTENDS SHELF LIFE

PICASSO



STANDARD FEATURES

- Advanced programmable recipe dryer
- Fan controls temperature & humidity, so product dries from the inside out

TRAY SIZES:

ASD50S
21.50"W x 23.75"D

ASD50/75/100/150/200
21.50"W x 23.75"D



STANDARD FEATURES

- Advanced programmable recipe dryer
- Programmable recipes for different shapes and thicknesses

TECHNICAL SPECIFICATIONS

Trays	20
Tray Size	31.50"W x 23.75"D
Pasta Per Tray	4 - 5 lbs
Fresh Capacity	80 - 100 lbs
Dry Capacity	60 - 80 lbs/cycle
Power	230V/3/60Hz, 16 Amps
Machine Dimensions	40"W x 41"D x 67"H
Shipping Dimensions	50"W x 52"D x 74"H
Machine Weight	411 lbs
Shipping Weight	700 lbs

TECH SPECS	ASD50S	ASD50	ASD75
Trays	50	50	75
Pasta per Tray	4 - 6 lbs	6 - 8 lbs	6 - 8 lbs
Fresh Capacity	300 lbs	400 lbs	660 lbs
Dry Capacity	240 lbs/cycle	320 lbs/cycle	480 lbs/cycle
Power	208-230V/3/60Hz, 5.5kW	208-230V/3/60Hz, 6.7kW	208-230V/3/60Hz, 8.5kW
Machine Dimensions	71"W x 41"D x 87"H	71"W x 55"D x 87"H	98.5"W x 65"D x 87"H
Shipping Dimensions	73"W x 44"D x 91"H	78"W x 65"D x 99"H	103"W x 70"D x 91"H
Machine Weight	710 lbs	1285 lbs	1390 lbs
Shipping Weight	925 lbs	1510 lbs	1650 lbs

TECH SPECS	ASD100	ASD150	ASD200
Trays	100	150	200
Pasta per Tray	6 - 8 lbs	6 - 8 lbs	6 - 8 lbs
Fresh Capacity	800 lbs	1200 lbs	1600 lbs
Dry Capacity	640 lbs/cycle	960 lbs/cycle	1280 lbs/cycle
Power	208-230V/3/60Hz, 12kW	208-230V/3/60Hz, 18kW	208-230V/3/60Hz, 20kW
Machine Dimensions	98.5"W x 102"D x 87"H	98.5"W x 110"D x 87"H	98.5"W x 134"D x 95"H

WARRANTY

One Year: For more information visit arcobalenollc.com/warranty.html



TRY BEFORE YOU BUY

In an effort to ensure success, we maintain a test kitchen where you can have your very own recipe tested for quality! Call for details.



TYPES OF FLOUR

There are a variety of flours which can be used to make fresh pasta!



SEMOLINA

Semolina flour is a granular flour with a light yellow color. It is produced from durum wheat, which is used almost exclusively for making pasta. It is also high in protein and gluten. When using Semolina flour in a extruder, you will be delighted with superior results!

DURUM WHEAT

Durum wheat has the ideal properties for making the best pasta. It is high in protein and gluten, which are both necessary for pasta making.

WHOLE WHEAT

Whole wheat flour is produced from grinding the full wheat berry (kernel). All parts of the wheat berry are used in the flour including the bran, germ and endosperm; which when milled, creates the speckled brown color that is a characteristic of the flour.

GLUTEN FREE

Gluten is the protein present in wheat flour and it can be challenging to bake without it. Some popular gluten free flours are white rice, buckwheat, millet, masa and chickpea flour.

DOUBLE ZERO

In Italy, flour is classified as 1, 0, or 00, according to how finely ground the flour is and how much bran and germ have been removed. 00 is the most highly refined flour and is talcum powder soft, yet holds its protein and nutritional value.

PURPLE BARLEY + EMMERSPELT + FARRO + BUCKWHEAT + RYE + CHICKPEA + RICE FLOUR + MORE!



MEET THE ARCOBALENO EXTRUDER FAMIGLIA!

HOME

AEX5

HOME MODEL

Up to 5 lbs/hr*

VITA

OTHER AVAILABLE COLORS:

- Green
- Orange
- Purple
- White
- Matte Black



● Red



● Pink



● Royal Blue



● Stainless



● Arcobaleno Yellow



● Tiffany Blue

*Extruder production varies by pasta shape

MEET THE ARCOBALENO EXTRUDER FAMIGLIA!

COUNTER TOP

AEX18

CHEFS' FAVORITE

Up to 15-20 lbs/hr*

JEMMA



AEX20

MAKING PASTA HAPPEN

Up to 20 lbs/hr*

EMMA



AEX30

IMPROVING ON THE ORIGINAL

Up to 30 lbs/hr*

STELLA



INDUSTRIAL PASTA EXTRUDERS

AEX50

PUSHING BEYOND EXCELLENCE

Up to 50 lbs/hr*

ARIA



AEX90

THE ARTISAN

Up to 90 lbs/hr*

GIA



AEX90M

THE ARTISAN TWO

Up to 110 lbs/hr*

GIA-M



AEX130

IN LOVE WITH PASTA

Up to 130 lbs/hr*

TIA



AEX130M

IN LOVE WITH PASTA

Up to 200 lbs/hr*

TIA-M



AEX440/440M

FACTORY DUTY

Up to 400 lbs/hr* (AEX440)

Up to 440 lbs/hr* (AEX440M)

DANIELLA-M



*Extruder production varies by pasta shape

THE ONLY FULL-SERVICE PASTA MACHINE MANUFACTURER IN NORTH AMERICA!



ARCOBALENO LANCASTER HEADQUARTERS
WE LOVE VISITORS!



ARCOBALENO'S ON-LOCATION TEST KITCHEN
COME MAKE PASTA WITH US!

TRY BEFORE YOU BUY
BY DEMONSTRATION



ARCOBALENO®
PASTA MACHINES

Making Pasta Happen!

©2026 Arcobaleno® Pasta Machines, LLC

Specifications subject to change without notice.

ARCOBALENO PASTA MACHINES, LLC
160 GREENFIELD ROAD | LANCASTER, PA 17601
ARCOBALENOPASTA.COM | 717.394.1402

Instagram X Facebook YouTube
@ARCOBALENOPASTA

AD_0326