

# EXTRUDER + DOUBLE MIXER | INDUSTRIAL

DANIELLA-M



ARCOBALENO®  
PASTA MACHINES

AEX440M  
FACTORY DUTY



## STANDARD FEATURES

- Automatically mixes and extrudes all-in-one process! Fresh, flavorful pasta has never been easier or faster
- Machine equipped with double mixer for continuous production
- The extruder can produce dough sheets, single or double output, with variable or fixed thickness (optional lasagna sheet die)
- Water cooling feature to help maintain a constant extrusion temperature with digital temperature readout
- Removable auger & stainless steel mixing arm for easy cleaning
- Best selection of brass dies guaranteed - **Over 300 shapes to choose from!**
- Factory and on-location training. The Only Full-Service Pasta Machine Manufacturer in North America!
- Touch screen control

## TOUCH SCREEN FEATURES

- Pre-set pasta shape recipes
- Different cutting speeds for pasta shape sizes
- Variable speed on mixing + extruding
- Alarms indicating emergency button pushed, errors, etc.

## OPTIONAL FEATURES & ACCESSORIES

- Pasta trays - Perforated - Dim: 15.5"W x 23.5"D x 2.75"H
- Pasta trays - Solid - Dim: 15.5"W x 23.5"D x 2.75"H
- APC20 Mobile pasta cart with 20 trays
- Automatic cutting knife for short pastas
- Lasagna Sheet Die Adjustable or Fixed Thickness
- Busiate die
- Penne Die with Special Cutting Knife
- Extruder dies with Teflon inserts
- Rolling Pins
- Vacuum System
- Optional water chiller mobile system

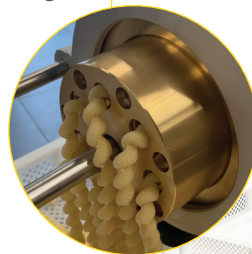

Shown with ATPD Dolly and Pasta Trays



TOUCH SCREEN CONTROL

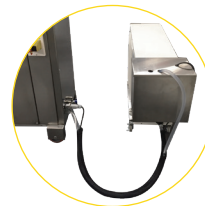

OPTIONAL WATER CHILLER MOBILE SYSTEM  
**No plumbing required!**



# EXTRUDER + DOUBLE MIXER | INDUSTRIAL



## AEX440M TECHNICAL SPECIFICATIONS

<b>Model</b>	AEX440M
<b>Hourly Production*</b>	Up to 440 lbs *Production varies by pasta shape
<b>Front Mixer Capacity (flour)</b>	50 lbs
<b>Front Mixer Production (flour+liquid)</b>	Up to 80 lbs/batch
<b>Top Mixer Capacity (flour)</b>	100 lbs
<b>Top Mixer Production (flour+liquid)</b>	Up to 130 lbs/batch
<b>Electrical Power</b>	220V/3/60Hz 36 Amps
<b>Machine Dimensions</b>	53"W x 75"D x 70"H
<b>Shipping Dimensions</b>	62"W x 86"D x 81"H
<b>Machine Weight</b>	1275 lbs
<b>Shipping Weight</b>	1727 lbs
<b>Shipping Class</b>	85

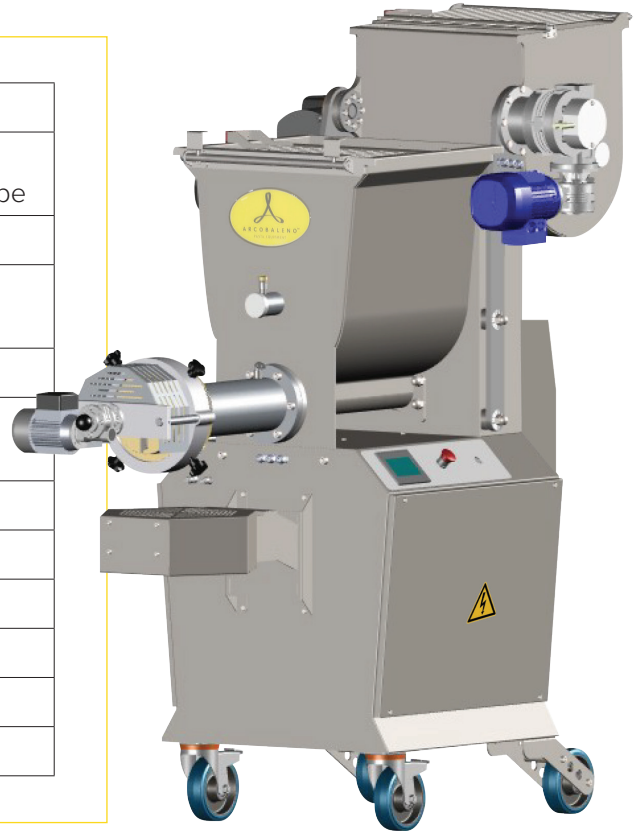

VARIABLE MIXING +  
EXTRUDING SPEEDS



PRE-SET PASTA  
SHAPE RECIPES



ALARMS INDICATING  
ERRORS

### ■ WARRANTY

**One Year:** For more information visit [arcobalenollc.com/warranty.html](http://arcobalenollc.com/warranty.html)



### ■ TRY BEFORE YOU BUY

In an effort to ensure success, we maintain a test kitchen where you can have your very own recipe tested for quality! Call for details.

